

## CIP System for Dairy Industry using PLC and SCADA

**Mr Prashant.A.Khade<sup>1</sup>, Prof. Mrs S.S.Patil<sup>2</sup>, Mr M.P.Takale<sup>3</sup>**

<sup>1,2</sup>Department of Electronics and Telecommunication Engineering,  
Rajarambapu Institute of Technology, Rajaramnagar, Sangli (M.S.), India

<sup>3</sup>Chanakya Logic Solutions, Kolhapur

Email: Prashantkhade071@gmail.com, Shaila.nalawade@ritindia.edu,  
Chanakyalogicsolutions@gmail.com

### Abstract

*In few years ago CIP automation system used in dairy industry for cleaning purpose of tanks, pipes dairy equipment etc. but present automation system is design for cleaning purpose of milk tanker. Generally milk tanker is filled with pasteurized milk and this milk is transport form one place to another place durining transporting interior surface of tanker become oily and this oily part is remove by different cleaning method such as hot water process, caustic soda process and cold water process when cleaning operation carried out more litters water is wastage and this wastage water of tanker is provided to drainage or farm so there is very harmful for farm after few years. At that time more energy is required for cleaning operation. This situation are occurs in dairy industry so we have design a new automation system which is more helpful for cleaning process of tanker. This system is easy to operate, economical affordable, save energy and resources.*

**Keywords:** CIP, Automation, PLC, HMI, SCADA

### INTRODUCTION

In few years ago CIP automation system used in dairy industry for cleaning purpose of tanker. In old techniques when cleaning process of tanker is carried out more litters of water and energy is wastage and they do not further reuse. They provided to farm or derange so this problems are happened in dairy industry durining process of tanker. So we have design a new system for cleaning process of tanker which is fully automatic, easy to operate and economically affordable. In present system design using PLC and SCADA .The main function of delta plc is to control the whole operation of system. Before transport of milk tanker is filled with pasteurised milk durining transport operation is take place

inside wall of tanker become oily. This oily part is removing by different process such as hot water process, caustic soda process and cold water process. This process is carried out in parallel format one by one. At that time simultaneously we can measure the ph of three tanks, temperature of three tanks and detect the level of three tanks.

### Block Diagram of System

Fig. 1 shows block diagram of proposed system using delta PLC. Delta PLC which is main controlling devices, and it's interfaced with different input and output devices, which is explain in following ways

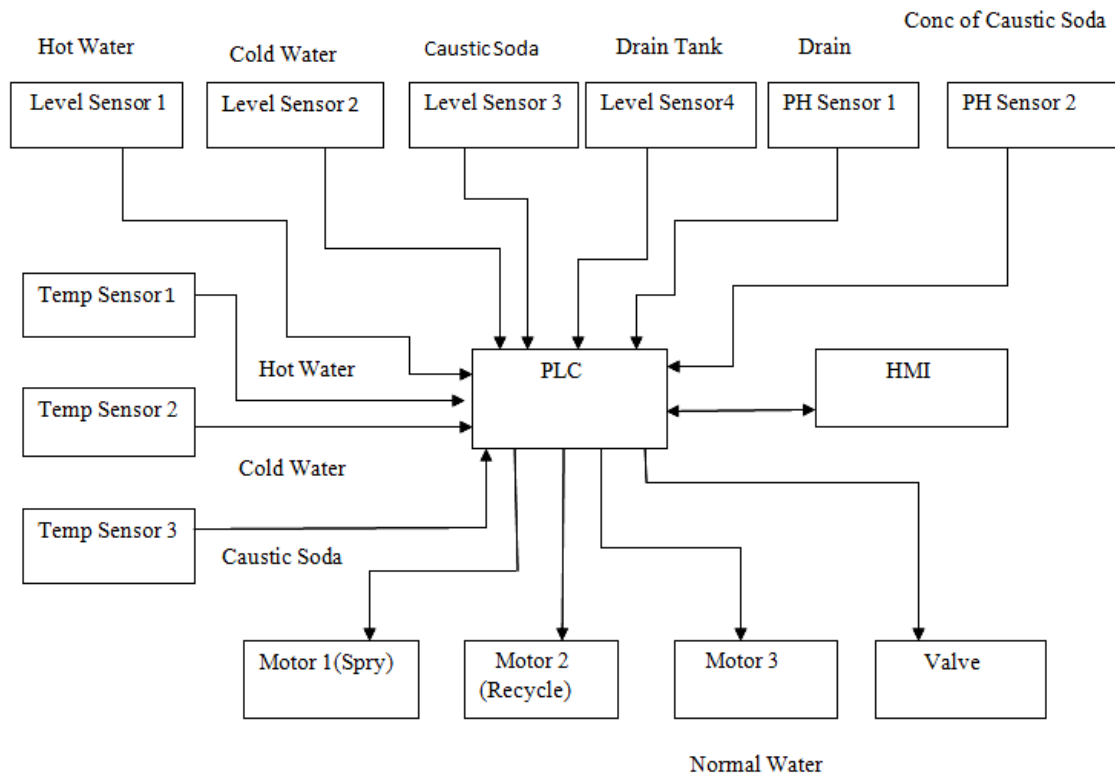

**Fig.1** Block Diagram of system

**INPUT DEVICE**

The proposed system consist of three sensors as,

- Temperature sensor: (Measure the temperature of Hot water and cold water)
- Level sensor : ( Detect the level of hot water, cold water and chemical of caustic soda)
- PH Sensor: (Measure the ph of collector tank and to concentrated of caustic soda)

**OUTPUT DEVICE:**

In this proposed system valve and motors are used for following purpose

- Motor 1: For Spray
- Motor 2: For Recycle of Water

- Motor 3: For Normal water

**Valve**

- Drain Valve of Hot water Tank.
- Drain valve of Caustic soda Tank.
- Drain valve of Cold water Tank.
- Normal water add valve of Hot water Tank.
- Normal water add valve of Caustic soda Tank.
- Normal water add valve of cold water Tank.
- Recycle valve of Hot water Tank.
- Recycle valve of Caustic soda Tank.
- Recycle valve of Cold water Tank.
- Drain valve of collector Tank.

**System Diagram**

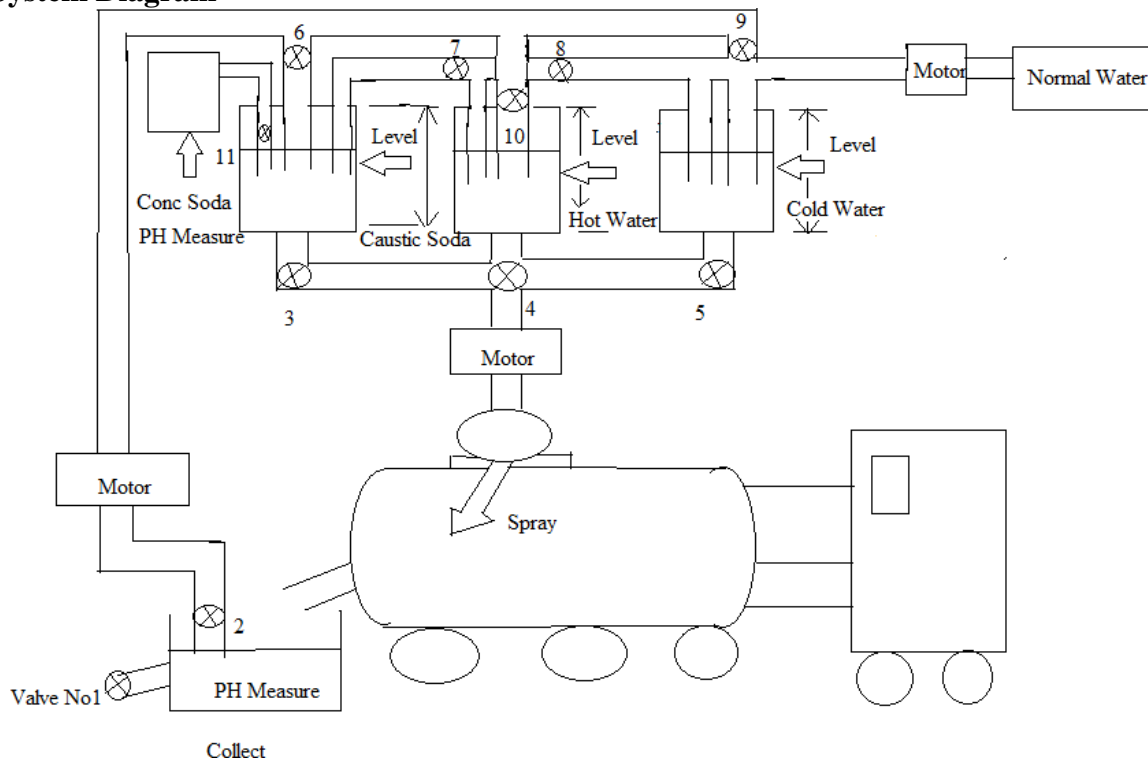

**Fig.2 System Diagram of CIP Process**

System diagram of CIP for dairy industry is mentioned as follows, generally CIP system is operate in parallel format. Durining transport of milk tanker filling with pasteurised milk and transport the milk from one place to another place at that time inside wall of tanker become oily this oily part is removing by different process such as hot water process, chemical of caustic soda process and cold water process durining washing of tanker. How operate the system automatically are explain brief in below,

**Step 1: Hot water Process**

When start switch is press then system become on and hot water process is start. Durining hot water process automatic open Drain valve of Hot water tank and spray motor on and spraying operation is take place inside wall of tanker. At that time three parameter check i.e. Ph of collector tank, temperature of hot water tank and detect the level of hot water tank. Durining hot water process water is reaches to

normal level then automatic on normal water pump and normal water add valve and fill the tank with normal water and stable the level of hot water tank. Also simultaneously measure the ph of collector tank when ph of collector tank become 7 then automatic on recycling valve of collector tank and recycling pump otherwise remaining valve of collector tank become on. After this process is completed reset the above process and automatic start second processes this process is brief explain in step no 2.

**Step 2: Chemical of Caustic Soda Process**

Durining caustic soda process automatic on drain valve of caustic soda tank and spray motor and spraying operation is take place inside wall of tanker. At that time check three parameter such as temperature of caustic soda tank, ph of collector tank, detect the level of caustic soda tank. Durining this process inside caustic soda of tank is reaches to normal level at that

time automatic on Normal water add valve and normal water pump and stable the level of caustic soda within tank. After cleaning process is carried out then measure the ph of collector tank when ph of water reaches to 7 then automatic on collector tank recycling valve and recycling pump. Otherwise remaining valve of collector tank become on. After this process is completed reset the above process and automatic start third processes this process is brief explain in step no 3.

**Step 3: Cold water Process**

During Cold water process automatic open drain valve of cold water tank and spray motor and cold water spray inside wall of tanker at that time three parameters will check i.e. temperature of cold water tank, ph of collector tank and detect the

level of cold water tank. During this process is carried out cold water is reaches to normal level at that time normal water add valve open and normal water pump become on and stable the level of water within tank. At that time simultaneously measure the ph of collector tank when the ph of water is nearest to 7 then automatic open the collector tank recycling valve and recycling pump otherwise remaining valve of collector tank become on after this process is completed automatic reset the process. When stop switch is press then automatic stop the above whole process. During the whole process is carried out more energy is required for this operation that causes we design new techniques to save the energy and resources. When cleaning operation is take place.

**Flow Chart of system**

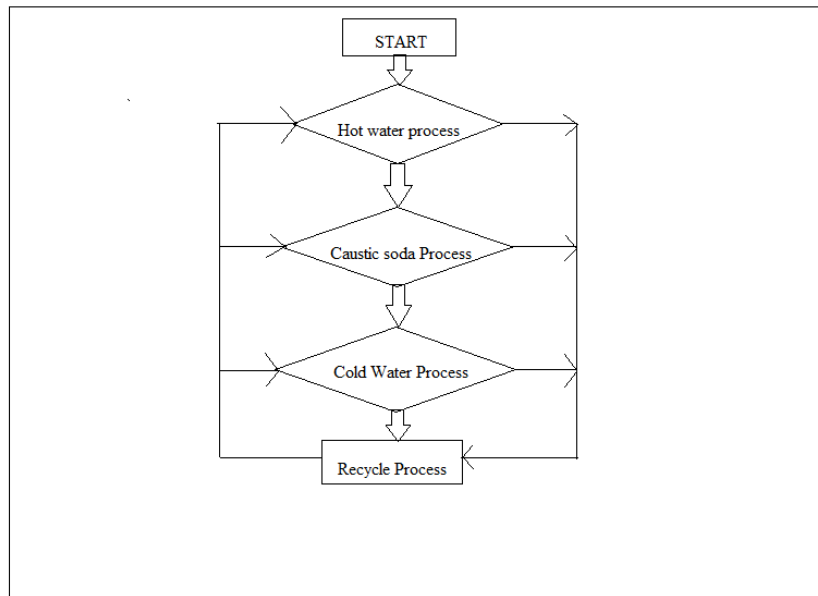

*Fig.3: Flow chart of system*

**Related work**

Gitta Septiani, Rivon Tridesman, Estiyanti Ekawati In this system describe biodiesel washing is part of biodiesel production process that aims to remove impurities contained in biodiesel. In this paper the process of biodiesel washing was

conducted as a liquid separation mini plant using mechanical stirring method. A capacitive sensor was utilized to detect interface which is used in the separation between two liquids, biodiesel and water. The process of washing or purification was carried out with 3 time iteration

programmable logic controller was used as controller device that serves to detect the sensor reading and operate the pump and valve in this biodiesel washing process.[1]

Bapusaheb Dhage, Archana Dhage In this system explains automation of CIP process in dairy industry CIP is crucial part to be automated in batch process industry. In many process industry after batch process is completion of batch the equipment cleaning is done by CIP process there are many method used for cleaning in industrial equipment like tanks in food and pharmaceutical industry such as 3 step, 5 step, and 7 step CIP. CIP in process industry like food dairy and present CIP used for cleaning and sterilizing of tanks valve, pipe with the help of acid, lye and consequent sterilization with high energy efficiency.[2]

Vibhuti. P. Patel, Mohan. R. Tilwalli Described the methodology of automation is the use of various control system for operating equipment such as machinery, process in factories, telephone network. In certain case industrial farm will work more focused on the use of the single PLC system design for that they limited number of input and output combination is available for the work. In certain situation engineers need more input and output combination than they must compulsory are another PLC and main problem was both PLC is not going to work together then this problem is occur at that time they design a new technique application based on two PLC and try to make double inputs and double outputs combination. that they must compulsory use another PLC. Also one application based on two PLC and try to make them as double input and double output combination.[3]

Nurgin Memisi, Slavica Veskovica Moracann and Jelena In given system explain principle of CIP washing process

in dairy industry generally this system has consist of automatic or semiautomatic. Basically this system design only for food processing method and microbiological food safety standards also it is very helpful for product safety and the same time unchanged quality from production to movement of consumption also preventing human diseases that are transmitted by food reducing the failure of finished product and improve their quality.[4]

Nighot Kanchan .B ,Kunjir Reshma A In this system design for Food and beverage industry by using PLC and SCADA the main purpose of system is reduce manual operation during cleaning process is take place the main advantage of system is reduce the production time and making plant environmentally safe.[9]

Amitha Thomas and C.T. Sathian The present system is design interior surface of pipeline by using different cleaning solution such as detergents sanitizers or disinfectants to achieve the most effective results and it is necessary to design of production process.[8]

## SYSTEM COMPONENT

The system components are classified into two categories such as software and hardware. They are classified as follows.

### WPL Soft Software

WPL Soft is program editing software made for Delta PLC series used under windows. Expect for general programming planning and other general function of windows, WPL Soft in addition has provided Chinese or English. Commentary editing and other special function for example survey, edit the listed register, set up the data read out, file saving and monitor and setup diagram of various contacts.

### DOP Soft Software

The all new and upgraded configuration software provides complete function and user friendly operator interface make editing easier than ever. With a whole a new level of design.

### HARDWARE COMPONENT

#### Delta SX series PLC

DELTA PLC DVP series the DVP SX series is as 10 points

(4DI+2DO+2AI+2AO) special main processing unit besides the same instruction and function as DVP SA series 2-CH 12 bit analog voltage\ current input and 2 -CH 12 bit analog voltage\current output are all bipolar. There is built in 2 digit 7 segment display corresponds to internal register directly to display PLC station or user defined code.



*Fig.4 Delta SX Series PLC*

### Features

- MPUPoints:10 points (4DI\2DO,2AI\2AO)
- Input Power: 24Vdc,5W
- AI\AORange:(+10V\ -10V,+20mA\ -20mA)
- Output Module:1.5A,250V ac,50\60 Hz
- Program Capacity: 8k Steps
- CommunicationPort:BuiltInRS232,RS 485
- Compatible with MODBUS ASCII\RTU communication protocol

### Delta DOP B series HMI

The Human machine interface (HMI) is interface between the process and the

operators in essence an operator dashboard. This is the primary tool by which operators and the line supervisors coordinate and control the industrial and manufacturing process in the plant. It survey to translate complex process variables into usable and actionable information. Displaying near real time operational information is the domain of the HMI. Visual process graphics gives meaning and context to motor and valve status, tanks levels and other process parameters. It gives operational insight into the process and enables control and optimization by regulating production and process forgets. Modern HMI

automatically focus the operator attentions on the problem. They must enforce stranded operating procedure and ensure timely, easy identification of abnormal conditions advanced situational awareness design must help the operators see what is happening, focus on the problem and

deliver relevant screens instantly. They must connect people, applications and machines for greater collaboration, efficiency and economy. The HMI must expose the relevant information to the appropriate people at right time, enabling them to make better decision.



*Fig.5 DOP B Series HMI*

#### **Features**

- Operating Voltage: DC +24V.
- DisplayType:7" TFTLCD(65535 Colour).
- Resolution: 800\*480 Pixels.
- Backlight: LED Back light.
- Display Size: 154.08\*85.92mm.
- Operating system: Delta real time operating system.
- MCU: 32 bit RISC Microcontroller.
- NOR Flash ROM: Flash ROM 128MB.
- SD RAM: 64 Mbytes.
- Backup Memory: 32 Kbytes.
- Buzzer: Multi tone frequency (2khz-4 khz).
- Serial COM Port: RS 232\ RS 485.

- Water proof Degree: IP 65.

#### **AC Motor**

The motor that converts the alternating current into mechanical power by using an electromagnetic induction phenomenon is called ac motor. This motor is driven by an alternating current. The stator and rotor is two important parts of ac motor stator is stationary part of the motor and rotor is rotating parts of ac motor. The ac motor has consisted of two type's single phase and three phases. Three phase motor are mostly applied in industry for bulk power conversion from electrical to mechanical for small power conversion the single phase ac motor mostly used.



*Fig.6 Rolled steel 56C Frame Motor*

**Features**

- Single Phase 230 V Ac.
- 0.33 HP to 1.5 HP.
- Electrically reversible.
- Capacitor start.
- 1800 RPM.

**Solenoid Valve**

**NC Two ways Solenoid Valve**

The two way valve can be either NO or NC in its operation. Normally closed valve is most commonly working in opposite fashion remaining closed until power source case it to open similarly NO valve operate vice versa



*Fig.7: NC Two way solenoid valve*

**Features**

- Stranded operating Voltage: 24v dc.
- Body: 303\304 stainless steel.
- Nominal Ambient Temperature Range: Dc (0<sup>0</sup>C to 40<sup>0</sup>C).
- Core Tube: 305 stainless steel.
- Shading Coil: Copper or Silver.
- Stem: PA (Normally open).

**WPL Soft programming Result:**

System is designed by using WPL Delta PLC software. The program is design by using PLC ladder programming using specific instruction.



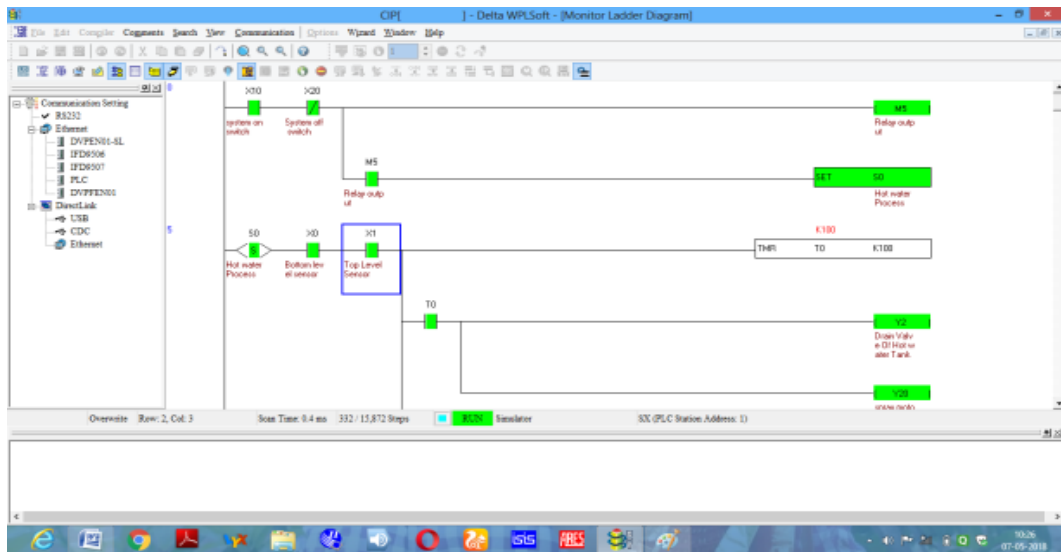

*Fig.8 WPL Soft programming Result*

The screenshot shows the Delta WPLSoft interface in Instruction List Mode. The main workspace displays a list of instructions:

Address	Instruction	Operand 1	Operand 2	Operand 3	Operand 4	Operand 5
000026	SET	S1				
000027	STL	S1				
000028	TMR	T2	K100			
000032	LD	T2				
000033	OUT	Y1				
000034	OUT	Y6				
000035	LD	T2				
000036	TMR	T3	K200			
000040	AND	T3				
000041	RST	S1				
000044	SET	S2				
000045	LD	M1000				
000046	FROM	K0	K1	D56		K1
000055	LD	M1000				
000056	TO	K0	K1	H0		K1
000065	LD	M1000				
000066	FROM	K0	K12	D10		K1
000075	LD	M1000				
000076	AND<=	D10	D56			
000081	OUT	Y21				
000082	LD	M1000				
000083	ZCP	K6	K8	D10		M0
000092	MPS					

*Fig.9 Ladder instruction list mode Result*

**HMI Programming Result**



*Fig.10 Control Panel of CIP System*

Control Panel of CIP system design by using DOP Soft HMI programming software in this program two switches is used for controlling operation in this programming. Also two indicators are

used in this system to indicate system is on or off. When system on switch is press at that time green indicator becomes on and indicates the system is on.

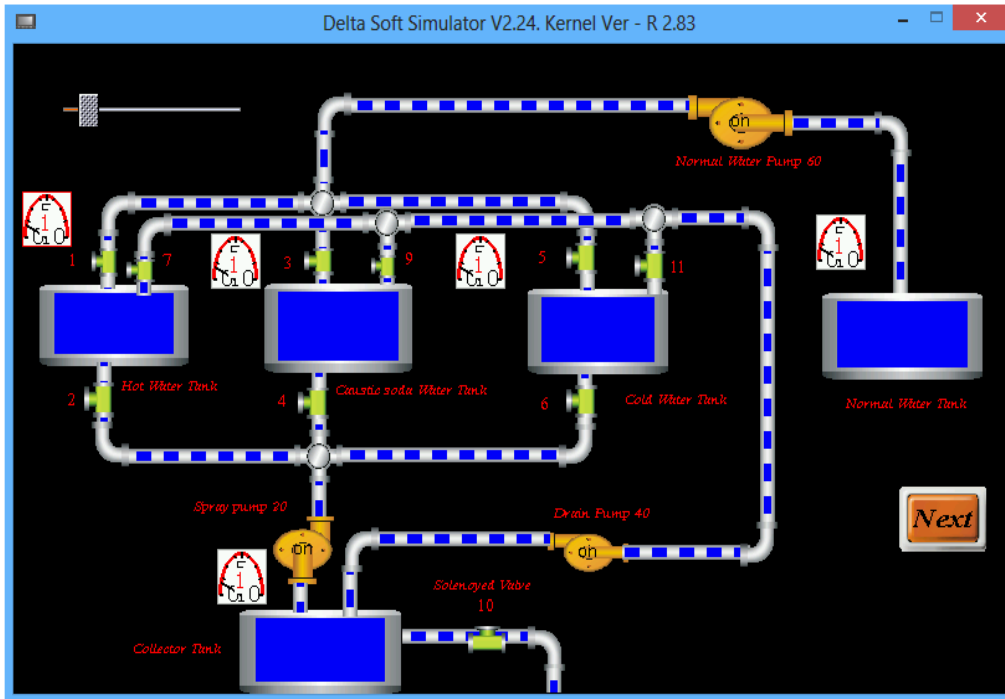

*Fig.11 CIP System ON*

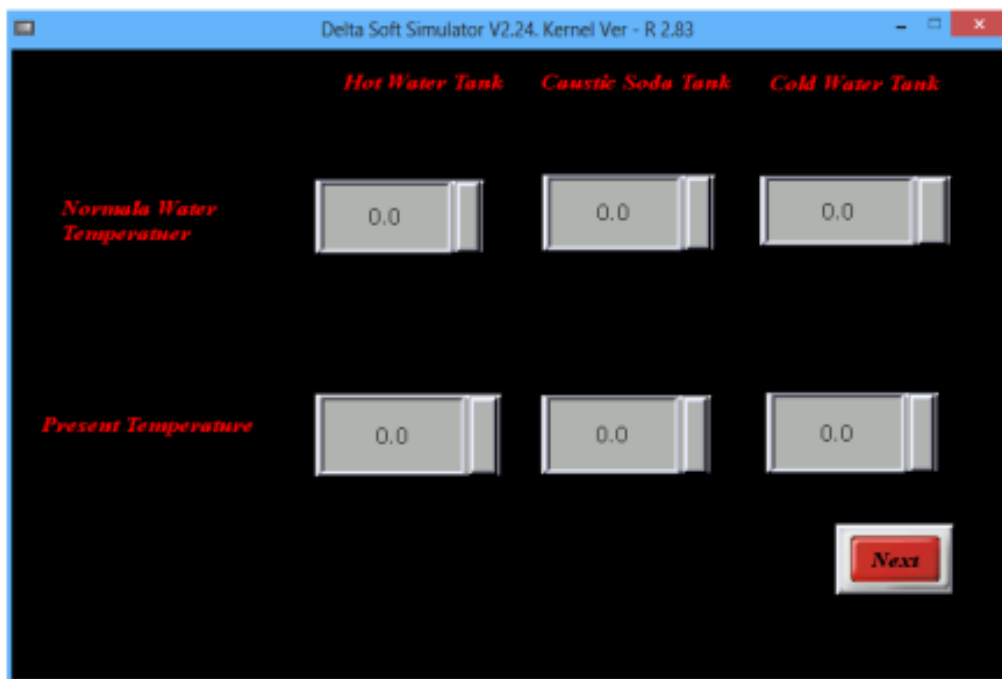

*Fig.12 Display of Temperature Result*



*Fig.13 Level Indication Result*



*Fig.14 Display of PH Result*

### Advantage and Disadvantage of system

#### Advantages

- Increased throughput or productivity.
- CIP improves the quality or increase predictability of quality.
- It improves robustness of process.
- Reduce the operation time and work handling time significantly.
- Difficult to access areas can be cleaned.
- Water consumption is reduced as cleaning cycles are designed to use the optimum quantity of water.
- The cleaning system can be fully automatic and save the energy.

- Cleaning costs can be reduced substantially by recycling cleaning solution.

#### Disadvantages

- CIP system becomes very costly.
- The cleaning system is fully automated therefore reduce the labour requirement.

### CONCLUSION

The automation done by this system provides a very effective way for reducing the wastage of water, energy, and time during cleaning process of tanker. This system promises a better accuracy, low

cost and lowering required time needed in the process. In the dairy industry if implement this system, then water and energy will be save and it is very helpful for dairy industry. Also this technique is very useful for other industry such as food industry, chemical industry, pharmaceutical industry for washing pipeline, equipment, tanks.

#### ACKNOWLEDGEMENT

I take pleasure in presenting my work done in the CIP for Dairy Industry. I would like to express my deep sense of gratitude to my guide Prof. Mrs S. S. Patil and Mr M. P. Takale for their valuable suggestion. I am deeply indebted to him for giving me the chance to do this innovative project providing constant guidance throughout this work. I acknowledge with thanks, the assistance provided by department staff, electronics faculty, staff, finally I would like to thank my colleagues, friends and at last but not least my lovely family who helped me directly or indirectly for the same.

#### REFERENCES

1. Gitta Septiani, Rivon Tridesman, and Estiyanti Ekawati, "Design and Implementation of Biodiesel washing automation system with set of sensors and programmable logic controller devices", International conference on sustainable energy engineering and application ,2015.
2. Bapusaheb Dhage,S.D.Bardable and S.D. Lokhande, "Automation of HVAC in pharmaceutical Industry, " IJETSR,ISSN ,2016,volume 3,pp,2394-3386.
3. Vibhuti.P.Patel,Mohan.R.Tilwalli, "DesigningCommunicationTechniques for PLC in Automation with considering cleaning Machine", International conference on computing methodology and communication, 2017.
4. Nurgin Memisi, Jelena Babic , "CIP Cleaning in the Dairy Industry", Elsevier procedia food science 5,2015,pp,184-186.
5. Peter.J.Fryer,Phillip.T.Robbins and Konstantina Asteriadou, "Current knowledge in hygienic design :can we minimize fouling and speed cleaning?", procedia Food science 1,2011,pp,1753-1760.
6. Martinscholer, Henning Foste, "Local analysis of cleaning mechanisms in CIP process," Elsevier Food and Bio products processing, 90, 2012, pp, 858-866.
7. Dr.Adhan Tamime, "Dairy science and technology consultant," 2007, Black well publication ISBN -13: 978-1-4051-2975-6.
8. Amitha Thomas ,C.T.Sathina, " Cleaning in place (CIP) system in dairy plant Review" ,IOSR- JESTFT, 2014, pp, 41-44.
9. Nighot Kanchan. B, Kunjir, Reshma A, "Automation of cleaning in place for food and beverage Industry using PLC and SCADA," IJAREEIE, 2016, pp, 3140-3146.