

Beamforming in Cognitive Radio Networks

B.Vidhya

Kongu Engineering College, Perundurai, India

E-mail: vidhya.b.ece@gmail.com

Abstract

Cognitive radio is a wireless communication technology which adds intelligence to the existing wireless communication scenario. This concept arises due to the heavy occupancy of frequency spectrum below 3 GHz which is caused by the ever growing demand for wireless services by the customers. This problem has placed a heavy burden to the resource allocation policy maker to accommodate between the demand and the available spectrum resources. In this paper, we address the problem of resource allocation in the context of cognitive radio networks (CRN). With the deployment of K antennas at the cognitive base station (CBS), an efficient transmit beamforming technique is proposed to maximize the Signal to noise ratio. We also used the smart antenna beamforming technique to enhance the error rate performance of the system. We simulated the result using MATLAB 7.5 and finally we analyzed the results for two cases, one when adaptive beamforming is used in the proposed system and second when adaptive beamforming is not used in the proposed system.

Keywords: *Cognitive radio, beamforming, SINR, smart antenna, wireless communication*

INTRODUCTION

The electromagnetic radio spectrum is a natural resource, the use of which by transmitters and receivers is licensed by governments. The proliferation of wireless services and devices for uses such as mobile communications, public safety, WiFi, and TV broadcast serve as the most indisputable example of how much modern society has become dependent on

radio spectrum. While land and energy constituted the most precious wealth creation resource during the agricultural and industrial eras, respectively, the radio spectrum has become the most valuable resource of the modern era. Notably, unlicensed bands (e.g., ISM and UNII) play a key role in this wireless ecosystem, given that many of the significant revolutions in radio spectrum usage have

originated in these bands and resulted in a plethora of new applications, including last-mile broadband wireless access, health care, wireless PANs/LANs/MANs, and cordless phones. This explosive success of unlicensed operations and the many advancements in technology that resulted from it led regulatory bodies (e.g., the Federal Communications Commission,

FCC, through its Spectrum Policy Task Force, SPTF [560]) to analyze the way the spectrum is currently used and, if appropriate, make recommendations on how to improve radio resource usage. Spectrum utilization is a function of time and location; it ranges from 15% to 85% according to the FCC.

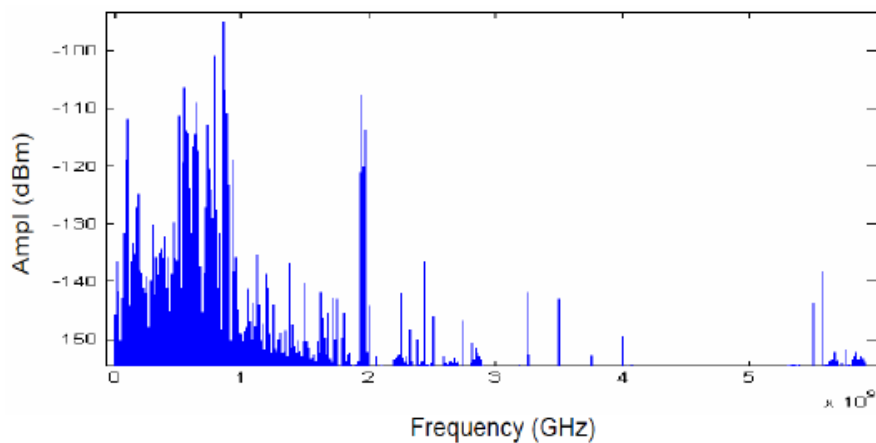

Fig. 1: Snapshot of Spectrum Utilization.

For example, cellular network bands are overloaded in most parts of the world, but many other frequency bands, such as military, amateur radio and paging frequencies are not. Independent studies performed in some countries confirmed that observation, and concluded that spectrum utilization depends strongly on time and place. Moreover, fixed spectrum allocation prevents rarely used frequencies (those assigned to specific services) from being used by unlicensed users, even when

their transmissions would not interfere at all with the assigned service.

COGNITIVE RADIO NETWORK

A spectrum hole is a band of frequencies assigned to a primary user, but, at a particular time and specific geographic location, the band is not being utilized by that user. Cognitive radio- inclusive of software-defined radio has been proposed as the means to promote the efficient use of the spectrum by exploiting the existence

of spectrum holes. Cognitive radio is an intelligent wireless communication system that is aware of its surrounding environment (i.e., outside world), and uses the methodology of understanding-by-building to learn from the environment and adapt its internal states to statistical variations in the incoming RF stimuli by making corresponding changes in certain operating parameters.

There are several ways to achieve the spectrum sharing with cognitive radio, such as space, time, frequency, and region. One of the strategies is to have the cognitive users to scan the spectrum and search for idleness, then access it when an unused slot is detected. Using baseband beamforming, it is possible to steer energy in the desired direction of the intended users, whose channels can often be accurately estimated.

BEAMFORMING

Beamforming has the advantage of limiting interference. Beamforming is a well-known spatial filtering technique which can be used to direct the communication transmission or reception energy in the presence of noise and interference. Beamforming allows the establishment of a communication link between the secondary users by exploiting

the absence of a licensed user's communication link in a certain geographical location, also known as the spatial spectrum holes. The definition of spectrum holes is the frequency bands which are assigned to primary users, which at a particular time and specific geographical location are not used by them.

Beamforming is to steer the signal in a desired direction. Beamforming can also be used in the uplink or downlink in a multiuser system to maximize the signal-to-interference-noise ratio (SINR) to a specific user [1–3]. One of the challenges is that beamforming can only be realized using arrays of antennas. In the case of traditional beamforming, we need arrays of antennas with a certain weight assigned to each of the array elements to direct the beam towards a specific direction. Beamforming technique can also be implemented using smart antenna algorithm.

Complex weights are selected from a library of weights that form beams in specific, predetermined directions, named switched beamforming. Here, the base station basically switches between the different beams based on the received signal strength measurements. If the

weights are computed and adaptively updated in real time, this is adaptive beamforming. Through adaptive beamforming, the base station can form narrower beams towards the desired user and nulls towards interfering users, considerably improving the signal-to-interference-plus-noise ratio. Transmit beamforming is a technique that uses multiple antennas to improve the performance in a multipath environment. A basic requirement for transmit beamforming is the use of multiple antenna elements at the transmitter, and the use of the measured wireless channel between the transmitter and receiver.

BEAMFORMING TECHNIQUES

Beamforming change the directionality of the array. When transmitting, a beamformer controls the phase and relative amplitude of the signal at each transmitter, in order to create a pattern of constructive and destructive interference in the wave front. While receiving, information from different sensors is combined in a way where the expected pattern of radiation is observed. In the receiver beamformer the signal from antenna is amplified by a different "weight". Different weighting patterns can be used to achieve the desired sensitivity patterns. As well as controlling the main lobe width (the beam) and the

sidelobe levels, the position of a null is controlled. This is useful in ignoring noise or jammers in one particular direction, while listening for events in other directions. A similar result can be obtained on transmission.

Beamforming techniques can be broadly divided into two categories:

1. conventional (fixed or switched beam) beam formers
2. adaptive beam formers or phased array
 - Desired signal maximization mode
 - Interference signal minimization or cancellation mode

Conventional Beamformers

Conventional beam formers use a fixed set of weightings and time-delays (or phasings) to combine the signals from the sensors in the array, primarily using only information about the location of the sensors in space and the wave directions of interest [4–6].

In contrast, adaptive beamforming techniques generally combine this information with properties of the signals actually received by the array, typically to improve rejection of unwanted signals from other directions. This process may be carried out in either the time or the frequency domain.

Adaptive Beamformers

As the name indicates, an adaptive beam former is able to automatically adapt its response to different situations. Some criterion has to be set up to allow the adaption to proceed such as minimising the total noise output. Because of the variation of noise with frequency, in wide band systems it may be desirable to carry out the process in the frequency domain.

Sonar phased array has a data rate low enough that it can be processed in real-time in software, which is flexible enough to transmit and/or receive in several directions at once [7]. Adaptive Beamforming is the process of altering the complex weights on-the-fly to maximize the quality of the communication channel. Here are some commonly used methods:

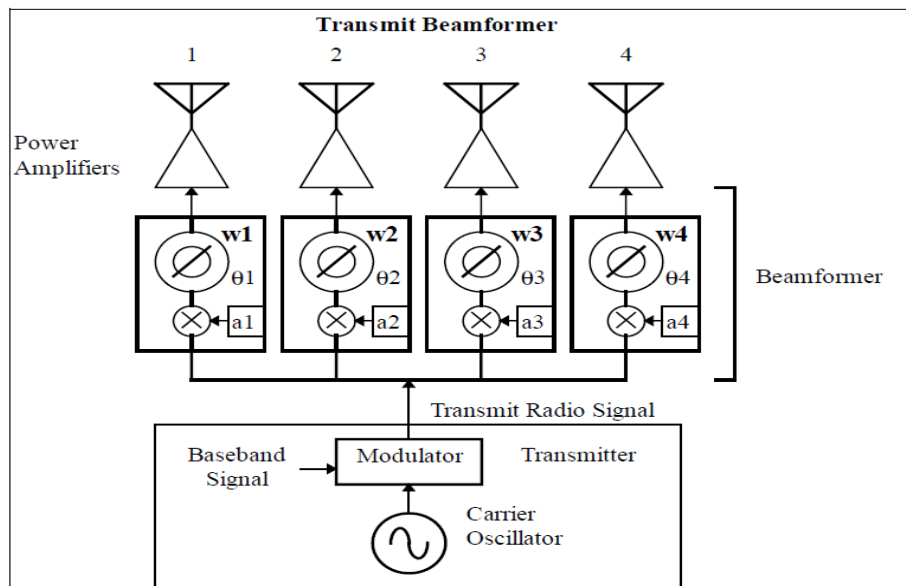

Fig. 2: Transmit Beamformer.

A beamformer for radio reception applies the complex weight to the signal from each antenna element, then sums all of the signals into one that has the desired directional pattern.

PRINCIPLE OF BEAMFORMING

The concepts of beamforming were first developed in the 1960's for military

applications in sonar and radar systems in order to remove unwanted noise from the output. It has been studied in many areas such as communications and seismology. Beamforming can be used for several purposes, such as signal detection, signal direction of arrival estimation (DOA), and enhancing a desired signal from its measurement corrupted by noise,

competing sources, and reverberation [8]. A beamformer is formulated as a spatial filter which operates on the outputs of a sensor array in order to form a desired beampattern. The signals induced at the different elements of an antenna array are combined to form a single output of the array. The operation of beamforming can be further decoupled into two sub-processes: synchronization and weight-and-sum. The synchronization process is to delay each of sensors output by a proper amount of time, so that the signal components coming from the desired direction are synchronized. The information needed for this process is the time difference of arrival (TDOA), which can be estimated from the array measurements using a time-delay estimation technique if it is not known a-priori.

The next process is the weight-and-sum step. In this step the signals received from the antenna array are weighted and then added together to form one output [9]. Both processes play an important role in controlling the array beampattern, the synchronization step determines and controls the steering direction, while the second process controls the beamwidth of the mainlobe and the characteristics of the sidelobes. Since the direction of the

beampattern generated by the array antenna is defined by the weight of each antenna elements, most of the attention to beamforming is often paid to the second step on determining the weight coefficient for each array [10–12].

In many applications, the weighting coefficients can be determined based on a pre-specified array beampattern, but it is usually more advantageous to estimate the coefficients in an adaptive manner based on the signal and noise characteristics. In the next section, we will give the basic of antenna arrays, and the basic theory of beamforming.

RESULTS & DISCUSSIONS

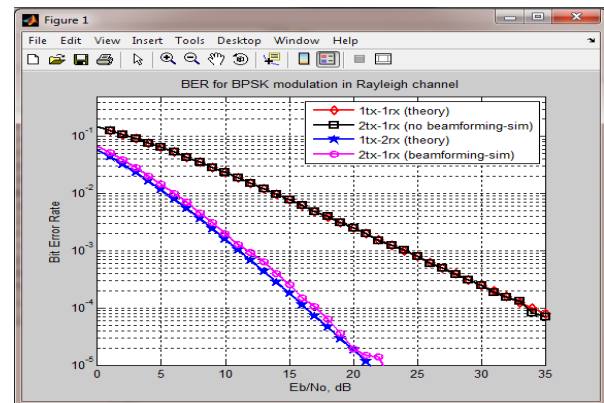

Fig. 4: BER Plot for 2 Transmit 1 Receive Beamforming for BPSK in Rayleigh Channel.

From the above graph, it is observed that sending the same information on multiple transmit antenna does not provide diversity

gain. Intuitively, this is due to the fact that the effective channel in a 2 transmit antenna case is again a Rayleigh channel; hence the BER performance is identical to 1 transmit 1 receive Rayleigh channel case. If the transmit symbols are multiplied by a complex phase to ensure that the phases align at the receiver, there is diversity gain. However, the BER performance seems to be slightly poorer than the 1 transmit 2 receive case. From this transmit beamforming, we observed that the BER performance is good in the case of more than one receive antenna.

Two results are provided to show the beamforming abilities of the LMS algorithm.

Case 1:

In this case the angle is arriving at 30 degrees and there are two interfering signals arriving at angles -20 and 60 degrees respectively.

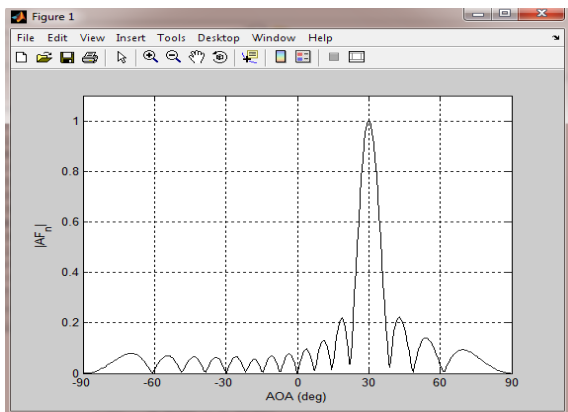

Fig. 5: Normalized Array Factor Plot For Case 1.

Case 2:

Another result shown in Figure is provided for the case where the desired signal is arriving at an angle of 0° and there are three interferers arriving at angles -40, -10 and 30 degrees respectively.

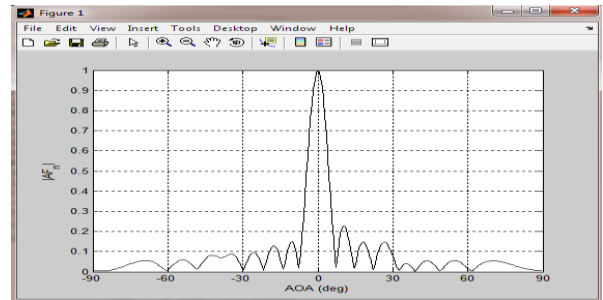

Fig. 6: Normalized Array Factor Plot For Case 2.

Case 3:

Finally it is considered that the desired user is arriving at an angle -45 degrees and an interferer at angle 45 degrees. The array factor for number of elements equal to 8 and 16 is computed and Figure below shows the array factor plots and how the LMS algorithm places deep nulls in the direction of interfering signals and maximum in the direction of the desired signal.

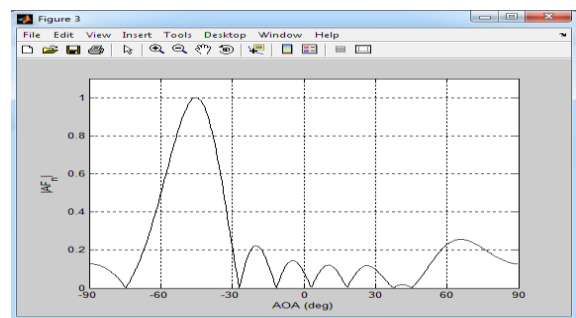

Fig. 7: Array Factor Plot when $N = 8$ and $d = 0.5$.

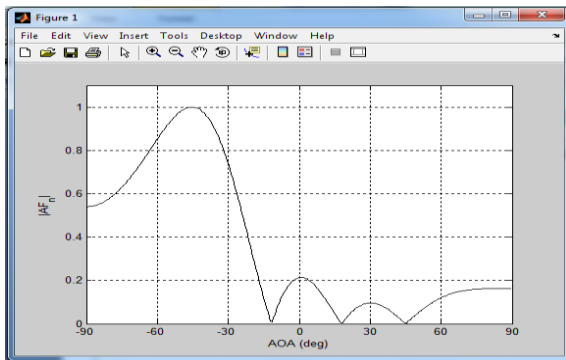

Fig. 8: Array Factor Plot when $N=8$, $d = 0.25$ and $AOA = -45$ degrees.

From the above graphs, it is clear that the spacing between the elements equal to half wavelength is the optimum value of spacing as it gives accurate result. The algorithm converges faster and stable for spacing between the elements equal to half wave length. The minimum mean square error is achieved after 50 iterations in case of $N = 5$ and after 30 iterations in case of $N = 8$ and after 10 iterations in case of $N = 10$. This shows that the algorithm converges faster when the number of elements in the array is increased.

CONCLUSION

In comparison to the existing wireless communication concept which virtually deploys fixed spectrum band for different wireless technologies, the concept of cognitive radio technology is indicative in bringing the wireless technology to new era. In this work, the performance of different beamforming techniques has been investigated. Although smart

antennas technology has been used in the third generation communication, the way it is proposed for cognitive radio technology is slightly different from the way it is used earlier. The difference is mainly from the point of view of side lobes requirement. In this paper, we used less complex adaptive beamforming algorithm, the “LMS”, for smart antenna system. LMS improves the convergence speed with small BER. In this algorithm individual good aspects of both the sample by sample and block adaptive algorithms are employed. Simulation results showed that the LMS algorithm provides remarkable improvements in terms of interference suppression, convergence rate and BER performance over that of other beamforming algorithms.

REFERENCES

1. Simon Haykin, Life fellow Cognitive Radio: Brain-Empowered Wireless Communications’, IEEE Journal on selected areas in communications. 2005; 23(2).
2. Cumanan, K. Krishna, R. Lambotharan, S. and Xiong, Z. ‘SINR balancing technique and its comparison to semidefinite programming based QoS provision for cognitive radios’, In *Proc. IEEE, VTC, Barcelona, Spain*. 2009; 1–5p.

3. Cumanan, K. Gershman, A.B. Lambotharan, S. and Musavian, L. 'SINR balancing technique for downlink beamforming in cognitive radio networks', *IEEE Signal Process. Lett.* 2010; 17(2): 133–136p.
4. Leila Musavian, *Member, IEEE*, and Sangarapillai Lambotharan, *Senior Member, IEEE* 'Joint Beamforming and User Maximization Techniques for Cognitive Radio Networks Based on Branch and Bound method', *IEEE Transactions on Wireless Communications.* 2010; 9(10).
5. Anh Tuan Hoang, MdHabibul Islam, and Ying-Chang Liang. 'Joint Power Control and Beamforming for Cognitive Radio Networks', *IEEE Transactions on wireless Communications.* 2008; 7(7).
6. Sung-Hyun Moon, Sang-Rim Lee. 'Sum-Rate Capacity of Random Beamforming for Multi-Antenna Broadcast Channels with Other Cell Interference'. *IEEE Transactions on Wireless Communications.* 2011; 10(8).
7. Gan Zheng, *Member, IEEE*, Kai-Kit Wong, *Senior Member, IEEE*, Shaodan Ma, *Member, IEEE*, and Tung-Sang Ng, *Fellow, IEEE* 'Robust Beamforming in Cognitive Radio', *IEEE Transactions on Wireless Communications*. 2010; 9(2).
8. Brodersen, R. Cabric, D. Mishra, S.M. Willkomm, D. and Wolisz, A. 'CORVUS: A Cognitive Radio Approach for Usage of Virtual Unlicensed Spectrum'. 2009.
9. Stutzman, WL. Thiele, GA. 'Antenna Theory and Design', 2nd edition, NewYork: John Wiley & Sons, Inc. 1998.
10. Neel, JO'D. (2006) 'Analysis and Design of Cognitive Radio Networks and Distributed Radio Resource Management Algorithms', PhD dissertation.
11. Fette B. Senior Scientist, General Dynamics C4 Systems, 'Cognitive Radio Shows Great Promise', COTS. 2005.
12. Al-Ardi, E M. Al-Mualla, M E. and Shubair, R M. Performance Evaluation of the LMS Adaptive Beamforming Algorithm used in Smart Antenna Systems', *IEEE.* 2005.