

Design of Suspension System for an All-Terrain Vehicles

Ajay Dorle^{1}, Darshan Darji¹, Shubham Nannavare¹, Oliver Dsilva¹,
Prof. Prashant k. Zaware²*

¹Students, ²Professor,

Department of Mechanical Engineering,

D Y Patil College of Engineering Academy, Ambi, Pune, Maharashtra, India

Email: ajaydorle9@gmail.com

DOI: <http://doi.org/10.5281/zenodo.2839588>

Abstract

The main agenda of this paper is to study the different parameters or characteristics of suspension system of an ATV. It is very much important for the suspension system that the wheel should be in contact with road surface, because there are some forces acting on the vehicle from downside, is referred as ground forces or road forces. We have designed front suspension as an A-Arm type and that of rear as an H-Arm type. Both the suspension systems are independent suspension systems. For these types of suspension systems, we required to calculate the important parameters like ride rate, roll rate, natural frequency, wheel rate, motion ratio, spring rate, damping ratio and factor of safety. By calculating all the parameters further we have done analysis of this parameters by solid work software and LOTUS Shark.

Keywords: Height of center of gravity, wheel rate, wheel travel, damping ratio, Toe in and Toe out angles, natural frequency, spring rate—whole suspension systems for an all-terrain vehicles

INTRODUCTION

Suspension systems are the backbone of the vehicle or ATV. It plays an important role for all types of vehicles. Since we are familiar with the suspension system, it is classified into mainly two types as follows

- Dependent suspension system
- Independent suspension system

a) Dependent suspension system

By considering the front side of an ATV, the rotation of one wheel of one side will cause to rotate the wheel of another side by means of wheel travel, it is said to be as dependent suspension system [1]. In this type of suspension system both wheels of same axles are rigidly connected to the same suspension system. The force acting on the one wheel affected the motion of another wheel.

- Ex - solid axle,
Leaf spring, Live axle.

*The main advantage of this type of

suspension system that the weight carrying capacity is more than the any other type of suspension system. So this type of suspension system is mostly used in heavy duty vehicle like trucks, Bus and in commercial vehicles.

b) Independent Suspension Systems

This system means that, the arrangement of the suspension in such a way that wheel on left and right side of the vehicle moves vertically up and down independently by means of travel on uneven surfaces. In other words, we can say that the force acting on a one wheel doesn't affect the other wheel. There is no any mechanical linkage available in between two hubs.

Ex - Double wishbones
MacPherson strut

*This type of suspension system gives better ride quality and handling due to less unsprung mass. The main advantage of this suspension system is that they require less space, low in weight they provide easy steering ability and many more [2].

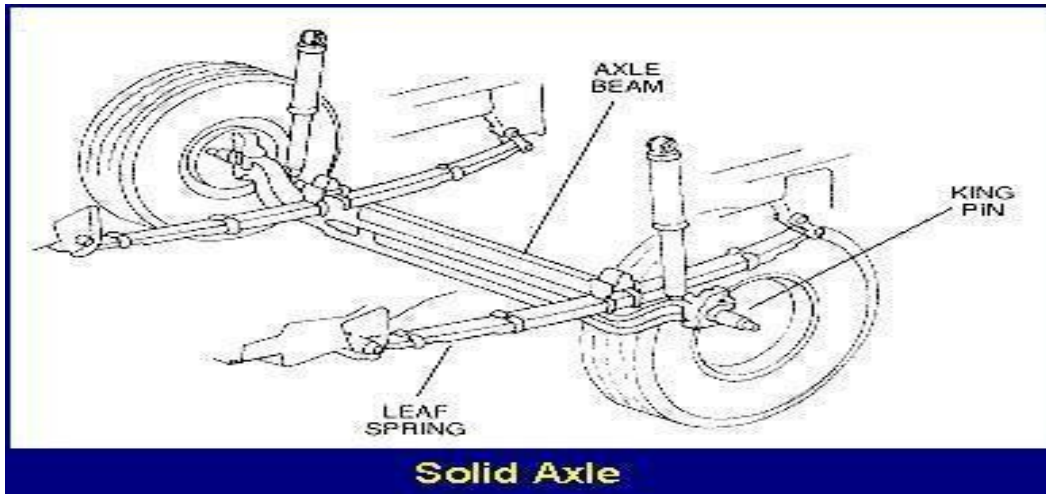

Solid Axle
Figure 1: solid axle.

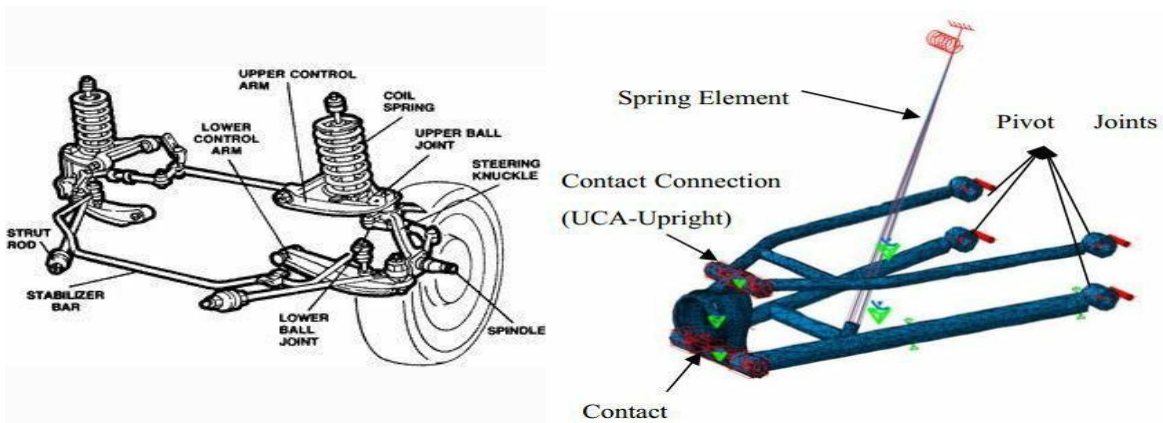

Figure 2: Double Wishbone Suspension System.

CALCULATIONS

Vehicles specifications

Table 1: Vehicles specification.

Front track width	53 Inch
Rear track width	55 Inch
Wheel base	56 Inch
Motion ratio	0.67
Height of centre of gravity	11 Inch
Distance of cg from front axle	36.4 Inch
Distance of cg from rear axle	19.6 Inch

1. Total sprung mass-

It is the total mass of the vehicle which acts on the wheel of the vehicle, said to be a total sprung mass. Hence total sprung mass= **161.22 kg**

2. Total unsprung mass -

The mass except than the sprung mass is said to be as a total unsprung mass of the vehicle. Hence total unsprung mass= **48.88 kg**

3. Total weight -

It is the addition of the sprung mass and unsprung mass of the vehicle. Hence Total weight=**2060.1 N**

4. Wheel travel -

It is defined as the movement of the wheel in vertically up and down direction as the wheel gets travel [3-4].

Table 2. Wheel travel for some vehicles.

Type of car	Wheel travel
Formula and sports car	+/-2 to 4
Indy type	+/- 0.5
Passenger car	+/- 4
Off road vehicle	+/- 12

5. **Spring constant -The load applied on the spring for unit deflection of the spring is called as spring constant or spring stiffness. Since, $w = \sqrt{(k/m)}$**
Where k = spring constant
m= sprung mass of the vehicle also we have equation,
 $w = 2\pi f$ where f = ride frequency
On equating both the equations we get
 $k = 4.\pi^2.f^2.m$

6. **Front spring constant**
Whole sprung mass of vehicle = **161.22 kg**
The sprung mass available at the front= **56.4270 kg**
The load acting on each wheel at front=**60.6590 kg**
 $k = 4\pi^2.m.f^2$
 $k = 4 \times \pi^2 \times 60.6590 \times 1.5^2$
k = 5388.1230N/m.

7. **Rear spring constant**
Whole sprung mass of the vehicle = **161.22 kg**

The sprung mass available at the rear = **104.7930 kg**
The load acting on each wheel at front= **112.6525 kg**
 $k = 4\pi^2 \times m \times f^2$
 $k = 4 \times \pi^2 \times 112.6525 \times 2^2$
k = 17789.36 N/m

CONCLUSION

Thus by using the above calculations and methodology for a suspension system, we have designed the suspension system and analysis has been done before manufacturing the original one by using ANSYS Software and LOTUS Shark software. We have designed the suspension system as on front side A- Arm type suspension system and on rear side H-Arm suspension system. After the fabrication of the vehicle we have tested the vehicle on uneven roads and terrains in order to check the stability of suspension System, weight distribution phenomenon and wheel travel.



Figure 3: completely designed and manufactured All-Terrain Vehicle.



Figure 4: Rear suspension system.

REFERENCES

1. William F Milliken and Douglas Milliken 1995. Suspension geometry. Race car vehicle dynamics. *Society of Automotive engineers*, Inc. 624-625.
2. Fox user manual https://www.ridefox.com/dl/snow/605-00-123_Rev%20B.pdf
3. V B Bhandari 2004. Springs. Design of machine elements. 3rd edition. Tata Mc Graw-hill Publications.400-406.
4. Thomas D. Gillespie, Fundamental of

vehicle dynamics (Society of automotive engineers).

Cite this article as:

Ajay Dorle, Darshan Darji, Shubham Nannavare, Oliver Dsilva, & Prof. Prashant k. Zaware. (2019). Design of Suspension System for an All-Terrain Vehicles. *Journal of Automation and Automobile Engineering*, 4(2), 14–17. <http://doi.org/10.5281/zenodo.2839588>