

Automatic Bottle Filling System Using PLC Based Controller

Md. Liton Ahmed¹, Shantonu Kundu², Md. Rafiquzzaman^{3}*

*^{1,2,3}Faculty of Mechanical Engineering, Department of Industrial Engineering and Management,
Khulna University of Engineering & Technology, Khulna, Bangladesh*

Email: rafiqbitr@yahoo.com

DOI: <http://doi.org/10.5281/zenodo.2604998>

Abstract

In this paper a bottle filling machine is introduced using Programmable Logic Controller (PLC) based controller in automation industry. The main aim of the paper is to design and fabricate a small and a simple filling system using PLC. The belt conveyor is used for moving the bottle. A dc pump is set to tank to control the flow of water. The position of bottle is detected by infrared sensor so that pump can be functioned at right time. When bottle is under the tank, the pump is started and bottle is filled by water. All the components perform well. This filling machine is cost effective and it can be used in small scale bottle filling systems such as coffee shops, juice shops and other beverage industries.

Keyword: *Automation, Easy technology, Low cost and smooth operation*

INTRODUCTION

Filling is defined as the method in which liquid is packed into the bottle such as water and other beverages. It can be automated by using Programmable Logic Controller (PLC) or Arduino. In the modern world, Programmable Logic Controller (PLC) is used for this purpose. PLC is the major element of the whole process. It is a powerful device to control the production system. It is used as a digital computer to automate industrial activities. It has many input and output unit, a CPU and a memory. It gives output results according to the condition of input. It is prepared for the replacement of relay circuit. The automation process is controlled according to the logics of programmed PLC. For inputs and outputs, PLC has a definite number of connections. The advantages of using PLC are smooth operation, low cost and high filling speed. To improve filling accuracy, it is necessary to apply PLC in automatic filling system. The process is controlled by ladder logic. Filling is controlled by using various methods using motor, level sensor, proximity sensor, conveyor belt, PLC, solenoid valve. This system can be made with arduino but flexibility will be less.

The arduino programming language is more complex than PLC ladder logic. The PLC ladder logic is symbol based that's why it can be changed easily. Lu, Y.-D., et al developed an automatic beverage filling machine by using PLC [1]. They used PLC to make the system flexible and to improve production rate. The ladder logic can be changed easily so they use PLC instead of arduino. Baladhandabany, D., et al. have studied on the principle of programmable logic controller and its importance on automation [2]. This process involves placing bottle on the conveyor and filling the bottle at a time. The purpose of this paper is to explain the process of filling more bottles at a time. For this purpose, stepper motor is used effectively to run the conveyor. It requires less number of sensor and it was cost effective. They have used ladder logic to control the whole system. M.H. Muhammad Sidik and S.A. CheGhani have made their paper on automatic liquid filling machine by using arduino to measure volume [3]. They studied on automatic filling machine used in food industry. This type of filling machine is available in the market which is hypocritical and expensive to clean up the cylinder piston that requires pneumatic

system. They used ultrasonic sensor instead of cylinder piston to make it easy and simple. They used arduino to control the whole system. They also used two solenoid valve to control the flow of liquid. Qijun Gong et al. developed an automatic liquid filling system by using image technology [4]. Simulink is used to make a simulation model which was used to control the filling system. This computer based technology reduced the accidents and labor costs. Kunal Chakraborty et. al. developed an automatic bottle plant [5]. This paper describes the fundamental stage of filling and capping method. The objective of this paper is to maintain the filling and capping operation at a time. To perform filling operation, bottles are placed on the conveyor. After completing the filling operation, they used a new set of empty bottles under the solenoid valve. They used PLC to control the system. Kulkarni, S.L. et. al. developed a PLC microcontroller for bottle filling system [6]. They studied on beverage as well as medicine in food industry and health care industry. As the demand of beverage and medicine are increasing day by day, filling is required to fill up this requirement. In health care industry, manual filling operation is dangerous. Manual filling in beverage industry is economical loss. It consumes more time than automatic filling system. To remove these disadvantages, they built up automatic bottle filling machine by using PLC. Kiran, A.R et. al. investigated the principle of PLC and its importance in automation [7]. They worked on PLC based automation which is very important in modern world. They proposed that PLC plays an important role in various industries for mass production with more accuracy and productivity. The engineers make ladder logic to operate PLC. They wanted to apply this micro controller in modern industries. H Ahuja, et al. developed an automatic filling machine [8]. In this time of industrial revolution, automation is needed to help

human being to do various work in industries. The competition among industries is rising day by day with their new products and their brands. In order to keep their product in market and deliver the product timely, automation is essential. They used PLC for this automation purpose. Schwager, A., et al developed automatic bottle filling machine by using PLC [9]. They studied on automation of industrial process which explains the manufacturing steps of automatic system in process development. It improves efficiency of filling system. Various elements are needed to control for filling system. They used PLC for this purpose. The goal of this paper explains the execution of industry 4.0 concepts in water refining plant by using PLC. They wanted to meet the market demand in short time by using this research. Silva, J.M et. al. Investigated an automatic foundry plant by using PLC [10]. In this paper, they have explained automation which controls the operating device. It minimized human effort, improved production rate, reliability and flexibility. It is useful for small and medium scale industries. They developed this process by using PLC. This type of industrial automation provides highly economic benefits.

Up to now many researchers studied on bottle filling system by using different techniques. The field of automation had a notable impact in a wide range of industries beyond manufacturing. Therefore, in this study an automated bottle filling system using PLC based microcontroller is designed and developed. The present machines will be that it can fill only a particular type of containers of specific volume and capping the bottle automatically. This machine can used in different industries like medicine, oil, chemical etc.

Materials and Methods

Flow chart of assembly of the proposed filling machine is shown in Fig.1.

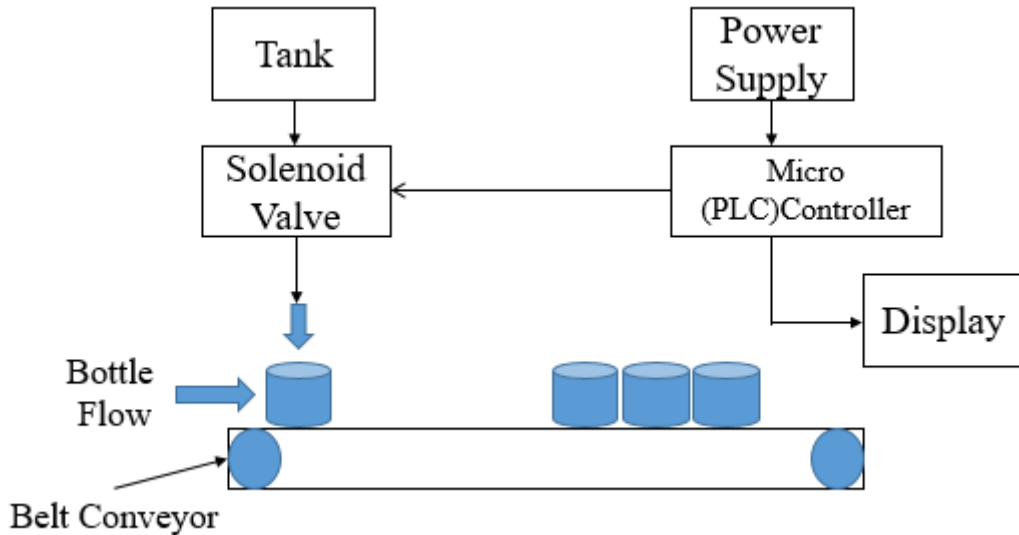

Figure 1: Flowchart for Assembly of filling machine

Working Principle

Flow chart of working principle is shown in Fig.2. The PLC ladder logic of this filling machine is shown in figure 3. If the button of the power supply is pressed, the conveyor motor will start to move. When the infrared sensor detects the bottle, the conveyor motor

stops to move and the dc pump will start to flow the water to fill the bottle. After completing the filling operation, the dc pump stops. Hence the conveyor motor starts to move and the bottle goes away from the dc pump. This process will be repeated if another bottle is sensed.

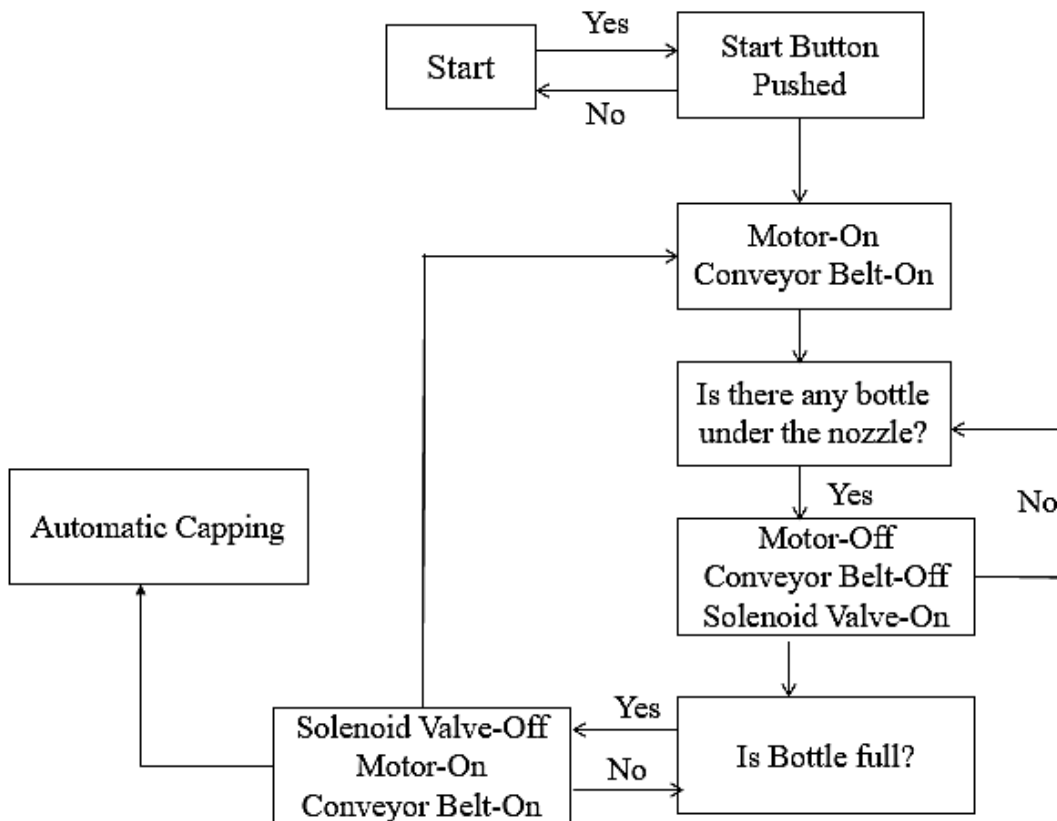

Figure 2: Flow chart of working principle of filling machine

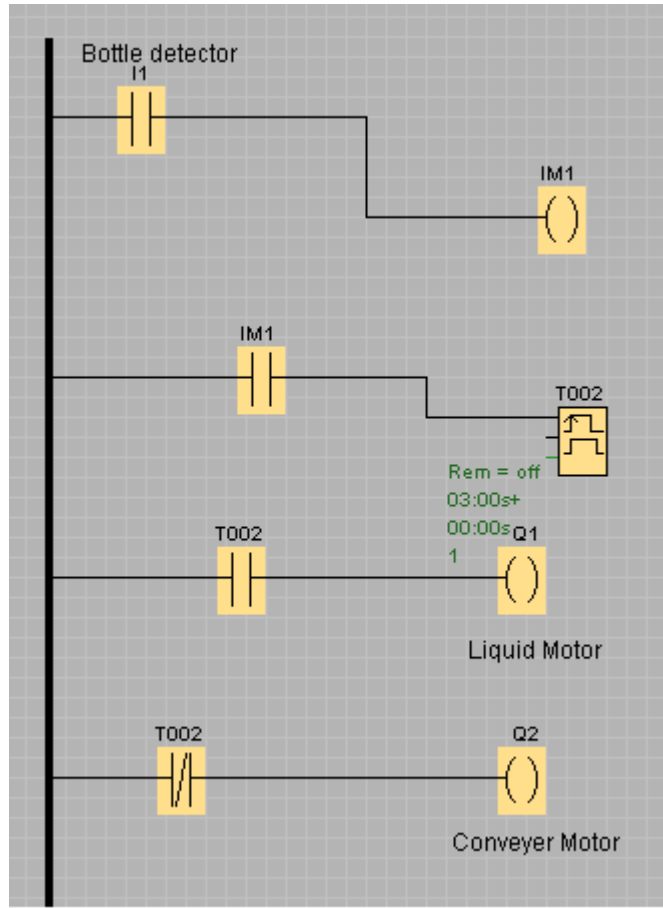

Figure 3: The PLC ladder logic of this filling machine

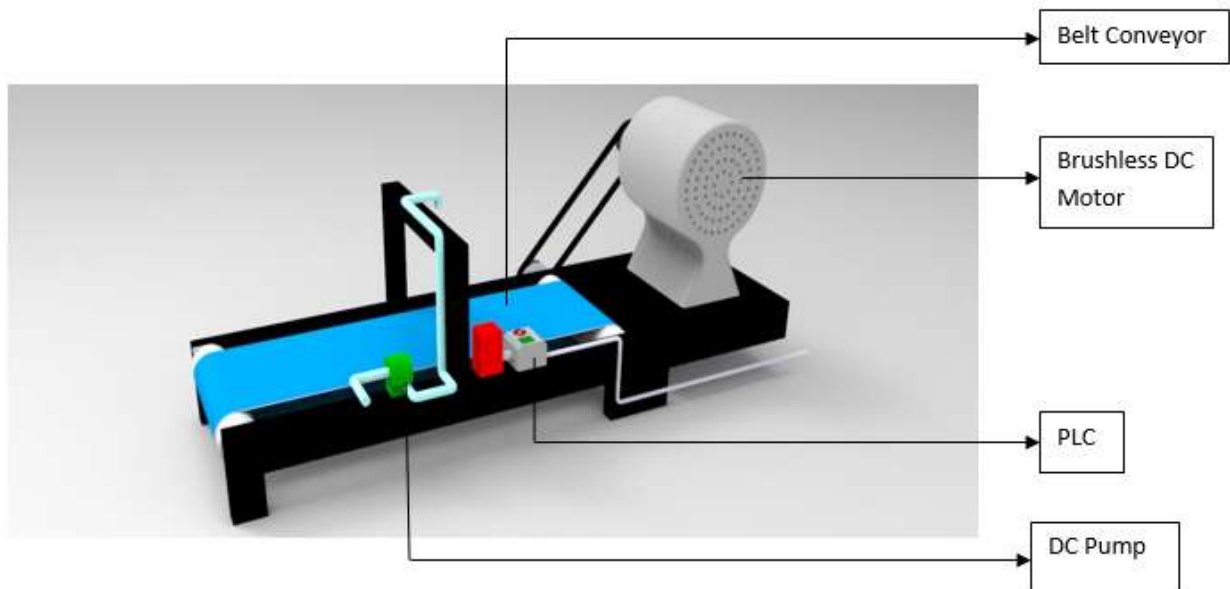

Figure 4: Proposed design of the filling machine

The model of the filling machine is shown in figure 4. It is made by solidworks 2016 software. The final construction is done according to this model.

Components of Filling Machine

Different components used in filling system are shown in figure 4.

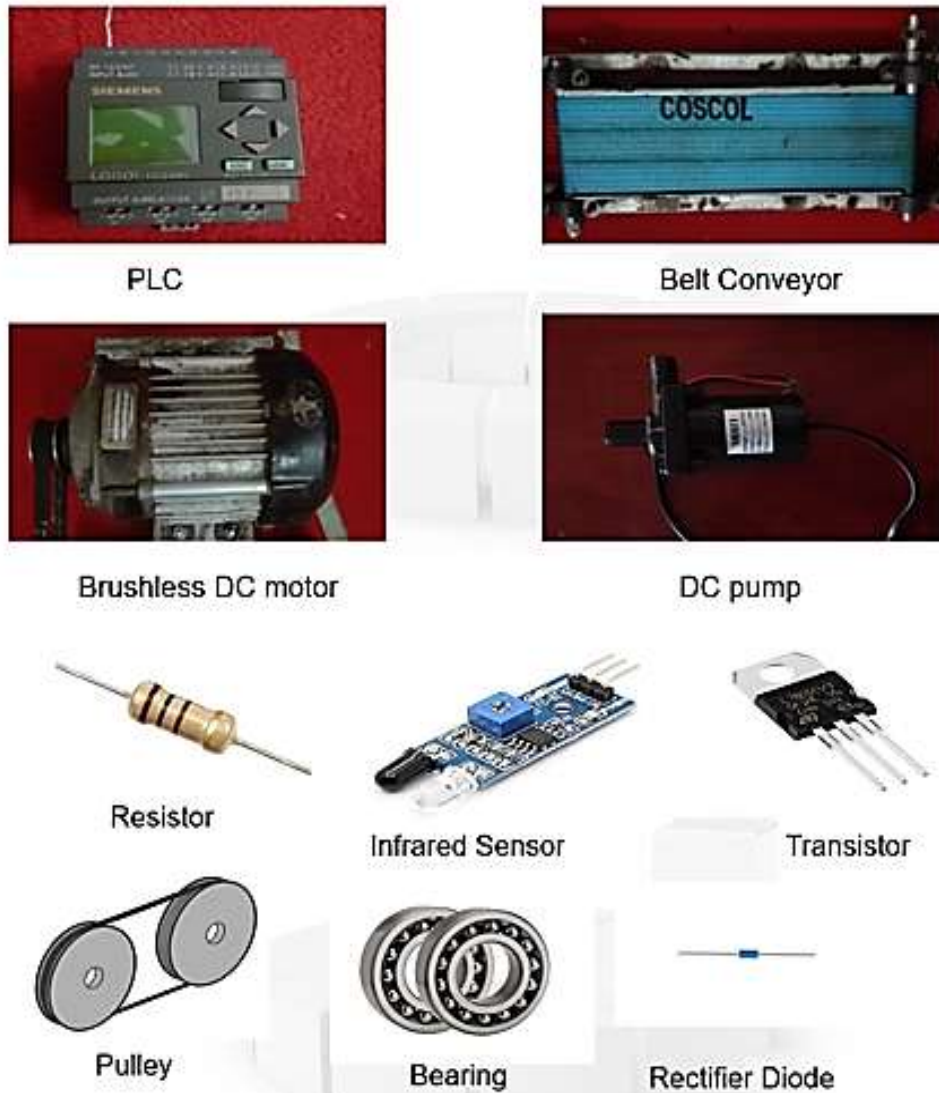

Figure 5: Different components used to construct the filling machine

Programmable Logic Controller (PLC): Programmable logic controller is a microprocessor based to store instructions and logics. In this project, PLC is used instead of arduino because it is more convenient to use PLC than arduino. Again, more flexible and more reliable operations can be performed by using PLC. The change of program is so much difficult in arduino micro controller whereas PLC ladder logic can be changed very easily if necessary.

Infrared Sensor: An infrared sensor may be defined as a sophisticated device which detects the objects which are nearly placed without contact point. In this study, this

sensor is used to detect the specific position of bottles on the conveyor belt.

Belt Conveyor: Conveyor is material handling equipment. It is used in mechanical sector for moving material from one place to another place. In this project, cotton belt is used because it is of low cost and more flexible.

Pulley: A pulley may be defined as a wheel which is used to support movement of belt. In this project, pulley is used to drive the belt of the conveyor.

Bearing: A bearing may be defined as a machine component which restricts relative motion and decreases friction

between moving parts. In this project, ball bearing is used to decrease rotational friction and to carry radial or axial loads. It is used to carry the bulk load.

Brushless DC motor: Brushless DC motor is also called as synchronous motor as shown in figure 10. It is operated by direct current which is inverted from alternating current by an inverter. The merits of this motor are high

speed, electric control etc. In this project, this motor is used to control speed manually.

DC pump: DC pump is used to move the water in different ways by using direct current from motor, battery or solar system. In this project, this pump is used for continuous water flow at low pressure. In this study, Transistor, Rectifier Diode, Resistor is also used for various purposes.

RESULTS AND DISCUSSIONS

Final Construction



Figure 6: Final Construction of an automatic bottle filling machine

The final construction of the filling machine is shown in figure 5. If the button of the power supply is pressed, the conveyor motor will start to move. When the infrared sensor detects the bottle, the conveyor motor stops to move and the dc pump will start to flow the water to fill the bottle. After completing the filling operation, the dc pump stops. Hence the conveyor motor starts to move and the bottle goes away from the dc pump. This process will be repeated if another bottle is sensed

Performance Test

The performance of this filling machine is satisfactory. The PLC is functioning correctly. The sensor is sensing bottles properly. The belt is running without any disruption. The bottles are filling accurately. The function of this machine is matched what is wanted. The performance test summary is as below.

1. The filling machine is performing well.
2. It can fill a bottle of 200 ml bottle in 3 sec.
3. It is a time based control and it can fill 67 ml per second.
4. The practical research result is much satisfactory.

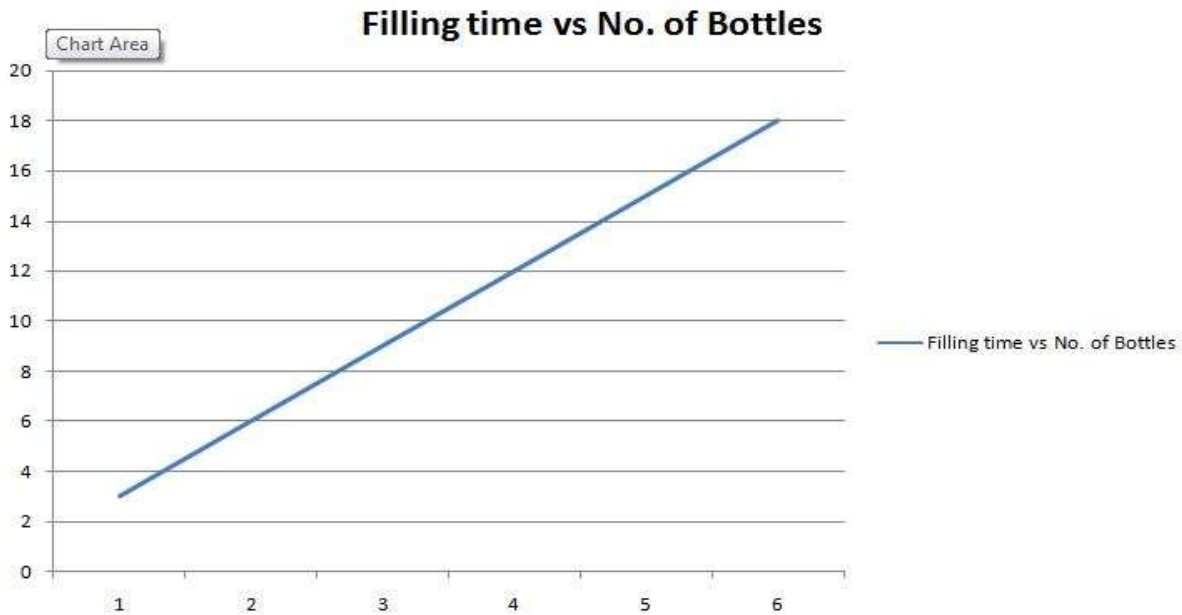

Figure 7: Graph 1: Filling time vs no. of bottles is shown

Filling time vs no. of bottles is shown in graph 1. A straight line is found as a result.

CONCLUSION

In this project, an automatic bottle filling machine is designed and constructed. All the components are performing well. It can fill 200 ml bottle in 3 second. It is a time based control system and it can fill 67 ml per second. It has some advantages over traditional filling process. This filling machine is cost effective. It saves human effort and time. It can be used in small scale bottle filling systems such as coffee shops, juice shops and other beverage industries.

ACKNOWLEDGEMENT

The authors are very much grateful to Khulna University of Engineering and Technology (KUET), Bangladesh and University Grants Commission (UGC), Bangladesh to provide necessary fund and lab facility for successfully completed this project.

REFERENCES

1. Lu, Y.-D., et al., *Analysis and Design of PLC-based Control System for Automatic Beverage Filling Machine*.

2. Baladhandabany, D., et al., *PLC based automatic liquid filling system*. International Journal of Computer Science and Mobile Computing, 2015. **4**(3): p. 684-692.
3. Sidik, M. and S.C. Ghani, *Volume Measuring System Using Arduino for Automatic Liquid Filling Machine*. International Journal of Applied Engineering Research, 2017. **12**(24): p. 14505-14509.
4. Gong, Q., *Application of Computer Image Technology in Automated Liquid Filling Machine*. Chemical Engineering Transactions, 2017. **62**: p. 859-864.
5. Chakraborty, K., et al., *Controlling the Filling and Capping Operation of a Bottling Plant using PLC and SCADA*. Indonesian Journal of Electrical Engineering and Informatics (IJEI), 2015. **3**(1): p. 39-44.
6. Kulkarni, S.L. and M. Elango, *Development of PLC based controller for bottle filling machine*, in *International Journal Of Innovations In Engineering Research And Technology*. 2016. p. 1-10.

7. Kiran, A.R., et al., *The principle of programmable logic controller and its role in automation*. International Journal of Engineering Trends and Technology, 2013. **4**(3): p. 500-502.
8. Ahuja, H., et al., *Automatic filling management system for industries*. International Journal of Emerging Technology and Advanced Engineering, 2014. **4**(1): p. 241-244.
9. Schwager, A., et al. *MIMO PLC: theory, measurements and system setup*. in *2011 IEEE International Symposium on Power Line Communications and Its Applications*. 2011. IEEE.
10. Silva, J.M. and B. Whitney, *Evaluation of the potential for power line carrier (PLC) to interfere with use of the nationwide differential GPS network*. IEEE Transactions on Power Delivery, 2002. **17**(2): p. 348-352.

Cite this article as:

Md. Liton Ahmed, Shantonu Kundu, & Md. Rafiquzzaman. (2019). Automatic Bottle Filling System Using PLC Based Controller. Journal of Advancement in Mechanics, 4(1), 17–24.
<http://doi.org/10.5281/zenodo.2604998>