

Smart Ambulance With Automated Traffic Control

Ritesh Sanodiya, V. S. Shashank, Pramod Gautam, Sonam Sahu

Department of Electronics and Communication,
Truba Institute of Information and Technology, Bhopal (MP), India
Email Id: shashanksundresh@gmail.com

Abstract

The present work proposes an ingenious traffic control system for emergency such as to control the traffic in case of ambulance. The proposed idea is to use an optimized and smart traffic control system in the heavy traffic area. In case of traffic, the lane of the ambulance can be made free and its corresponding lane can be made stuck with the help of the advanced traffic control system as discussed in the present work. Here, the basic circuit model, working principle and hardware circuit components are described to give a better understanding of Smart Ambulance traffic control system.

Keywords: *Smart Ambulance, Traffic Control System, LEDs, astable multivibrator, traffic density.*

INTRODUCTION

In the present work, a mix of remote movement checking and control framework is utilized, in which a police man can control the stream of activity from a remote area through his PC. He can produce every one of the three activity signals (red, green and yellow) on a tick of mouse as it were. Additionally he can redirect the stream of activity by checking it on his PC screen through camera. The program written in VC++ controls the activity stream in both the conduct programmed and physically. In programmed mode movement stream is controlled by foreordained eras and in manual mode a police man can open or close any path relying upon the activity thickness on every path. It implies that, if

on one path activity is overwhelming when contrasted with the other path, then that path is open till some other path has a more prominent traffic density. One more included component is alert framework. At whatever point any driver needs to drive out in red light the laser shaft will be hindered and it will ring an alert in police station.

Hardware circuit

The circuit as shown in the circuit diagram tab completes logical circuit of traffic light control system. The main components are 2 input quad OR Gate IC 74LS32, NOT gate IC 74LS04, current driver IC ULN2003A and last timer IC 555.

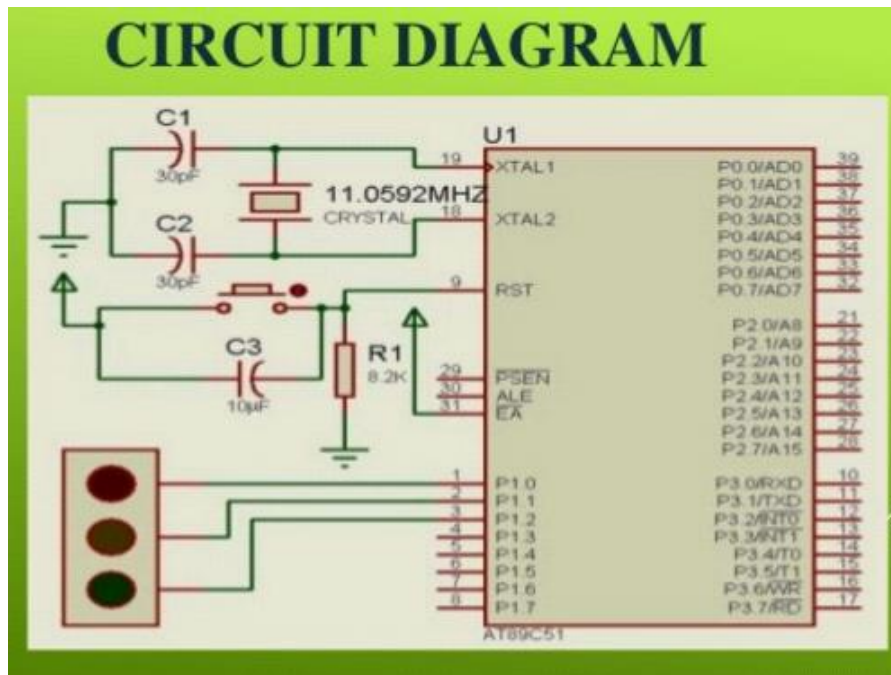

Fig.1. Logical Circuit Of Traffic Light Control System.

Connections: Both the inputs of all four OR gates are connected to all eight data pins D0-D7 of 25 pin D-type female connector. Four green LEDs are connected with all even pins D0-D2-D4-D6 and yellow LEDs are connected with all odd pins D1-D3-D5-D7. The output of all OR gates are given to all four RED LEDs through NOT gates. Further the even pins also drives relays (RELAY1A-2A-3A-4A) through current driver chip. The relay gives supply to IC555 that is connected in single shot mode. LDR is used to detect laser beam.

LOGICAL OPERATION

We already know how the traffic light system works. At a time, only one LED will glow red, green or yellow. Now to drive total 12 LEDs we have only 8 data lines. Now as we know when green is ON red is OFF and vice versa, we are a single line for both signals by connecting green LED directly to data lines (D0-D2-D4-D6) and red LEDs via NOT gates. Thus, we can connect 4 red and 4 green totals 8 LEDs with 4 data lines and rest 4 are connected with yellow LEDs.

Now there is one set of three LEDs one for each lane. We know when any one led is ON other two should be off. To implement this logic we have only two data lines. Let's understand the operation with first section because it is same for all four. For first section we have two data lines D0 & D1. When you apply high logic to D0 pin the green led LED2 will ON. As the same high logic passes through OR gate, so the output of OR gate will be high. This high output is inverted by NOT gate and this will switch OFF red LED LED1. To OFF yellow LED LED3, we shall apply low logic to D1 pin. So at a time only one that is green LED is ON. Now letting D1 pin 0 (low logic) if D0 is also made 0 the OR gate will produce 0 output and after inversion it will be 1 (high logic) so red LED will glow other two will be off. Now if we make D1 pin 1 the Yellow LED will glow. This high logic passes through or gate and again produces high output so red LED will be again OFF. So again, only yellow LED will glow other two will remain off. To understand the operation better pls refer the table.

Table 1.

D1	D0	LED
0	1	Green
0	0	Red
1	0	Yellow

Depending upon this logic, we have to generate different codes to open consecutive lanes, to switch ON all yellow lights etc. All the codes are given in table given below.

Table 2.

Hex codes	operation
01 (0000 0001)	first lane (LED2) is open all other are closed because other lanes have red light
04 (0000 0100)	second lane (LED5) is open all other are closed because other lanes have red light
10 (0001 0000)	third lane (LED8) is open all other are closed because other lanes have red light
40 (0100 0000)	fourth lane (LED11) is open all other are closed because other lanes have red light
AA (1010 1010)	all yellow LEDs are ON red and Green LEDs are off.

Alarm system: Complete alarm system is built around timer IC 555. As told before it is connected in single shot mode. LDR is used to detect laser beam. As the laser beam continuously, strikes on LDR 555 gets continuous trigger from LDR. So its output is continuously high. And that's why buzzer is off. Now when laser beam is interrupted 555 does not get trigger so its output goes low and the buzzer rings. Now when one lane is open the high logic drives current driver chip ULN2003A and

it will energizes the relay. So it will cut off the supply of alarm circuit and that's why when laser beam is interrupted alarm will not ring.

This completes the hardware part. One more thing you can add is that blinking yellow light circuit that I have implemented but not cover in this article. It is an astable multivibrator built using 555 Timer with 1 sec ON time and 1 sec OFF time.

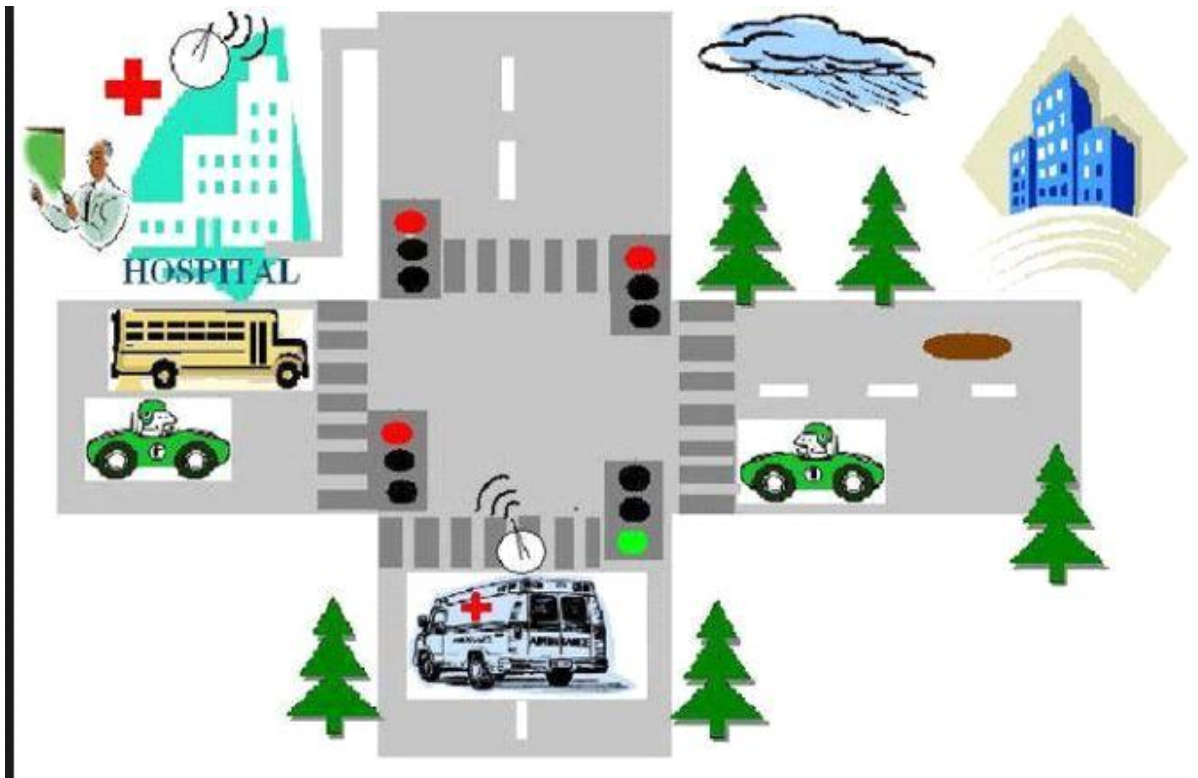

Fig 2.

CONCLUSION

With the help of this project we are able to conclude that we can send the ambulance in time to the hospital even in the massive traffic and save the life of the patient. Our advanced circuit can play a major role to achieve this things it should give the particular signal which is in the ambulance through transmitter to the traffic lights so its lane become free and its corresponding lane become stuck so it become the path of ambulance without any further traffic due to this components 2 input quad OR Gate

IC 74LS32, NOT gate IC 74LS04, current driver IC ULN2003A and last timer IC 555.

REFERENCES

1. Ashutosh Bhatt, Traffic Control System, Engineers Garage (online solution)
2. Dr. J. N. Patel Bhavin and Tandel Jiten, Polytechnic, Amreli under my guidance
3. Introduction to Relays, Anjali Sethiya, Engineer Garage.