

Rail Track Monitoring and Intelligent Security System for Indian Railways

Seema S. Patil^{1}, Shilpa S. Patil¹, Onkar J. Renake¹*

¹*Student, Department of Electronics and Telecommunication Engineering, Sharad Institute Of Technology College Of Engineering, Yadrav, Maharashtra, India*

*Email: *seemapatil597@gmail.com*

DOI: <http://doi.org/10.5281/zenodo.2629572>

Abstract

Nowadays, rapid growth in population has increased the means of transportation, due to the reasons as supplying of goods and services and increase in employment level. Out of which, the mode and medium of convenience and transportation are railways, but nowadays people are facing the railway accident problem. The 60% of accidents in railways are due to track problems which lead to derailment. In our proposed system, the endanger of the crack in railway tracks has been detect by passing DC supply. Whenever a continuous signal of proper supply will not be received by microcontroller, it will indicate that there is a crack in the track and GPS meanwhile will sense the location of the derailment. Thus, getting the indication and status of crack in the track will avoid the interditory movement of the train. Accidents involving trains are often the result of mechanical failures and human error, and often it is a combination of both. For saving the life of human, endangered due to human error, we have used sensor module to detect the proximity of the train along the station, which would result in prior intimation of arrival as well as departure of the train and fourth the controlling action that is turning on and off the gate will take place without manual interfacing. We have also designed water level control system, water level from each bogie is monitored by the train driver accordingly that level is conveyed to the next station. So on the next station the respective tank will get full without any delay. The proposed system helps to reduce risk and endanger of failure of rail tracks, saving human life due to human errors.

Keywords: *Infrared sensor (IR), Microcontroller, GPS, GSM, LCD*

INTRODUCTION

Most of the commercial transportation in India is being carried out by the railway network and therefore, any problems in the same have the leads to induce major damage to the economy. In terms of the reliability and safety parameters, Indian railway has not yet reached the international standards. The main problem about railway analysis is detection of cracks in the track [1]. The 60% of accidents in railways are due to track problems which lead to derailment of the proposed paper work and detect the exact location of the derailment of the track

without any human intervention and sends the message to train driver using GSM [2]. If these accidents are not controlled at early stages, they might lead to a number of derailments resulting in a heavy loss of human life and property. Another major problem resolved relative to railway analysis is closing and opening of gate upon arrival and departing of train. The proposed system provides effective solution on this problem by using IR sensor module. This will be making an effort to save the human life due to human errors and impish and insincere practices [3].

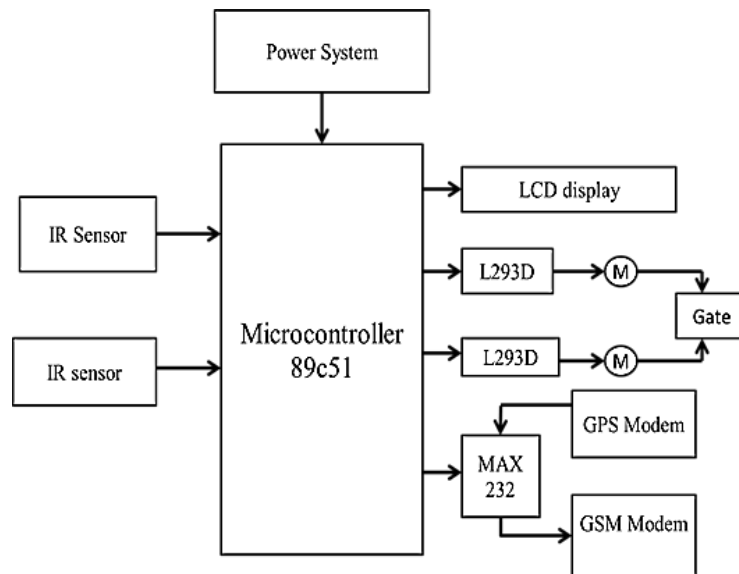

Figure 1: Block diagram.

PROPOSED MODEL

Objective

The proposed model has made an effort in resolving three current scenarios which causes threat to human life and property. The scenarios are enlisted below:

- Detection and monitoring track derailment.
- Automatic gate control.
- Monitoring of water level control of each bogie in the train.

Detection and Monitoring Track Derailment

The widely used mode and medium of convenience and transportation are railways but nowadays people are facing the railway accident problem due to track problems or derailment of tracks which lead to derailment. Thus this necessitated us in designing our proposed model [4].

This project can help to detect the cracks or breakages in railway tracks by providing prior intimation and alert signal is thus sent to the train operator. The crack is detected by passing Dc supply through track. Whenever a continuous signal of proper supply has not been received by microcontroller, it will indicate that there is a crack in the track and meanwhile GPS will send the exact location of the

derailment or cracked track. Thus, getting the indication and status of crack in the track will avoid the interdutory movement of the train [5].

Saving the Life of Human Due to Human Error

The objective of this paper accomplishes and provides an automatic railway gate control at a level crossing by eliminating the manual interference. The main aim behind proposing this objective is to reduce manual interference and also to reduce the accidents that occur due to human error, implementing this objective will thus save human life due to human error. In the existing system once the train departs from the station, the stationmaster informs the gatekeeper about the arrival of the train through the telephone. Once the gatekeeper receives the information, he closes the gate depending on the timing at which the train arrives: Hence, if the train is late due to certain reasons, then gate remain closed for a long time causing traffic congestion near gate. By employing the automatic railway gate control at the level crossing the arrival of the train and departure of the train is detected and the traffic congestion can be minimized [6].

This project utilizes four long range IR sensor modules. Two pair of transmitter and receiver is fixed at upside at a level higher than a human being in exact alignment and similarly the other pair is fixed at down side of the train direction. Two Sensors are fixed at 1km on both sides of the gate and remaining two sensors are placed at 500m from previous sensors. Assuming that the train is coming from right side direction then sensor1 is activated first and when train crosses second IR sensor at that time gate motor is turn on in one direction and gate is closed and remains closed until the train crosses the gate and reached left side direction of sensor. Here we will be using DC motor to open and close the gates. Now when the train is again detected at other IR trans-

receiver the gates are opened. We will be using L293 driver IC to control the motor i.e. opening and closing of the gates. When left side receiver gets activated motor turns in anticlockwise direction and gate opens and motor stops [7].

Monitoring of water level control of each bogie in the train.

Water is an essential parameter in the train. Water level sensor is situated in the tank of each bogie. If the water level is below threshold level, through GSM the message will be send to the bogie incharge and upcoming station incharge as well as. With our proposed system, at all times level in the water tank is maintained and also it saves the driver time [8, 9].

COMPARATIVE STUDY OF EXISTING AND PROPOSED SYSTEM

Table 1: Comparative study.

Sr. No	Existing Model	Proposed Model
1	Opening and closing of gate is done manually.	Opening and closing of gate is done automatically and manual interference is reduced.
2	No provision of human safety due to human error.	Provision of human safety is done.
3	Track detection and prior intimation is not made.	Track detection and prior intimation is made.

Specifications

IR Sensor

Principle

An infrared sensor is an electronic instrument which is used to sense certain characteristics of its surroundings by either emitting and/or detecting infrared radiation.

Specifications:

Output power: +4 dBm typ

Single power supply: 1.8 V to 3.6 V

GSM:

Principle:

The GSM system is a frequency- and time-division cellular system, each physical channel is characterized by a carrier frequency and a time slot number. Cellular system is designed to operate with group of low-power radios spread out over the

geographical service area. Each group of radios serve MSs presently located near them. The area served by each group of radios is called a CELL. Uplink and downlink signals for one user are assigned different frequencies, these kind of technique is called frequency division duplex (FDD).Data for different uses is conveyed in time interval called slots, several slots make up a frame [3].This kind of technique is called time division multiple access (TDMA).

Specifications

Frequency-850MHZ/
900MHZ/1800MHZ/1900MHZ

Baud rate- 9600bps

Power requirement- 4.5V to12V

Current requirement- <590mA

Operating temperature- -40o C to +85oC

GPS

Principle

The Global Positioning System (GPS) consists of a network of 24 broadcasting satellites orbiting the earth at a height of 20,200km. GPS also consists of receivers on the ground, which listen to and interpret the transmissions of the satellites. A GPS receiver must be locked on to the signal of at least 3 satellites to calculate a 2-D position (latitude and longitude) and track movement. With four or more

satellites in view, the receiver can determine the user's 3-D position (latitude, longitude and altitude).

Specifications

- GPS Receiver – Lassen IQ
- 16 channels
- L1 frequency
- Antenna- Omni- directional 6db
- Connector- SMA Coax Bulkhead Jack
- Synchronization- PPS, PPM, PPH
- GPS protocol- RS 232

RESULT

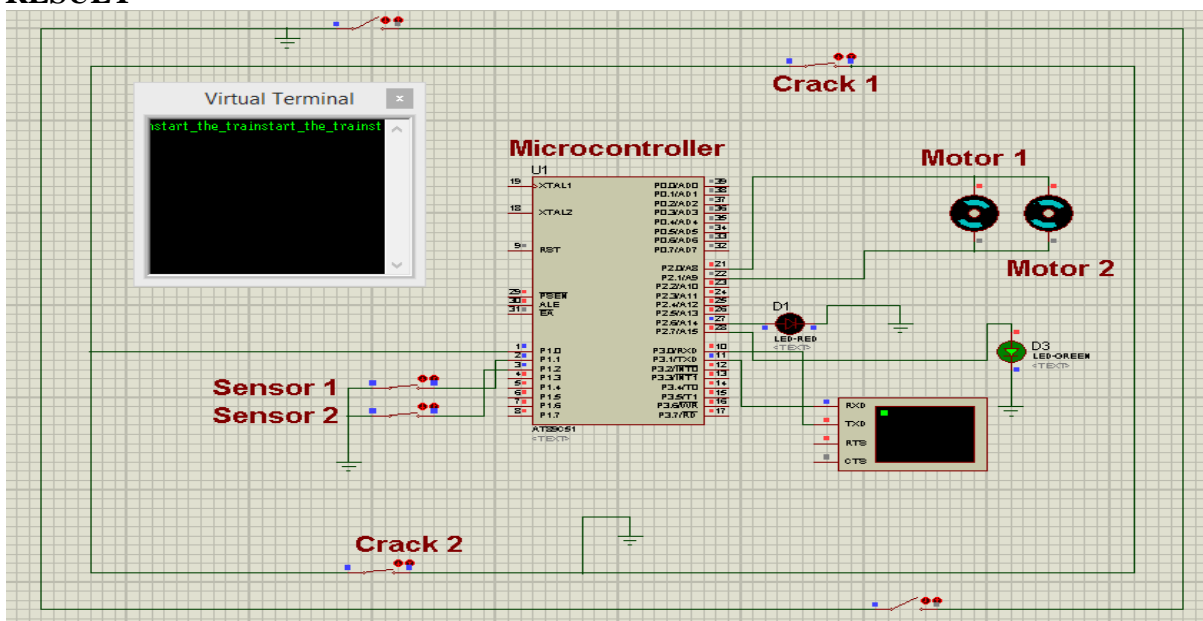

Figure 2: Simulation of system.

CONCLUSION

The purpose of designing and implementation of the proposed system

will help to reduce risk and endanger of failure of rail tracks, saving human life due to human errors.



FUTURE SCOPE

We can monitor all tracks at a time by using IOT.

REFERENCES

1. QiaoJian-hua, Li Lin-sheng, Zhang Jing gang (April2008), "Design of Rail Surface Crack- detecting System Based on Linear CCD Sensor," *IEEE Int. Conf. on Networking, Sensing and Control*, Volume 14, Issue 4, pp. 961-970.
2. Railways overview- a technical magazine.
3. Sharan Kumar, Dr. Jayadevappa, Santosh D. Bhopale (April 2014), "Implementation of Image Segmentation using FPGA", *International Journal of Advancement in Research & Technology*, Volume 3, Issue 4, pp. 2700-2702.
4. The 8051 microcontroller and embedded systems "Muhammad Ali Mazidi"
5. Selvamraju Somalraju, Vigneshwar Murali, Gourav Saha, Dr.V.Vaidehi (May, 2012), "Robust Railway Crack Detection Scheme (RRCDS) Using LEDLDR Assembly," *IEEE Int. Conf. on Networking, Sensing and Control*, Volume 6, issue 3, pp. 453-460.
6. A complete reference of Micro Controllers, "Natwar Singh".
7. Sharan Kumar, Dr.Jayadevappa, Radhika R. Naik (April 2014), "Implementation of Image Edge Detection Using FPGA", *International Journal of Latest Technology in Engineering, Management & Applied Science (IJLTEMAS)*, Volume III, Issue IV, pp. 69-72, ISSN 2278-2540.
8. Pradeep Raj (2012), "Increasing accidents in the unmanned level crossing of the railways",
9. Ahmed M, Farooqui H, J K Pathan "3G based automation using GSM communication", *International Journal of Research in Environment Science and Technology*.