

Experimental Analysis on Temperature Variation of Exhaust Gases in Reflective Muffler

¹Deepjyoti Basak, ²Nitin Bagre

^{1,2}Assistant Professor,

¹Mechanical Engineering, Parul Institute of Technology, Vadodara, Gujarat

²Mechanical Engineering, Prestige Institute of Technology, Indore, Madhya Pradesh

Email: djeratones43@gmail.com

Abstract

Mufflers are used in wide variety of application. In automobile industries its use is to reduce the noise, temperature, back pressure and harshness of exhaust gases. Upgrading in emission norms and reduce the environmental problems like noise pollution makes a hard venture to layout the excessive overall performance and efficient mufflers for every automobile. To fulfil the requirement, empirical, analytical, and numerical techniques had been used. Value and efficient gas performance are some other crucial parameter for the method designer to supply a muffler that may meet the emission requirements. Noise from engines is one of the important factors for high noise pollution, as the number of vehicles increases every day. Several theories and equipment have been developed to reduce the problem in last few years. Diesel engines are noisier as compared with gasoline engines because the combustion of diesel engines produces extra harmonics than slower combustion of gasoline. Exhaust noise of fuel engine without muffler is within the variety between ninety to 100 decibels whilst the diesel engine without mufflers degrees among a hundred to 125 decibels.

Keywords: Mufflers, Exhaust devices, Engine

INTRODUCTION

Engines in which combustion takes vicinity internally a class of a heat engine. In such type combustion takes area in an isolated chamber, in which chemical power of fuels transformed into mechanical energy by adiabatic compression manner. This mechanical power is transmitted to the engine output shaft by way of converting reciprocating movement of piston to rotational motion. The gases produced for the duration of the combustion is emitted out by the assist of silencer and mufflers. [1]

Historically noise attenuation device is known as silencer, even as the dimensions of mufflers are smaller as compared to silencers. [2] The traditional way to construct the muffle is to combine the growth chamber and perforated board or perforated pipe, are with fairly exhaust resistance however very terrible in the

performance of decreasing noise for low frequency noise band. [3, 4]The foremost motive of muffler is to reduce the noise from engine exhaust. Cars without muffler produces large amount of undesirable noise. [5] The exhaust gases ought to be discharged into the surroundings with minimum limit. The again strain at low cost via proper designing of exhaust gadget. high again strain outcomes in better bhp loss at particular speed, Dilution of sparkling price with exhaust gases, improved fuel consumption. Back strain may be reduced by proper design which may also come to be cumbersome and steeply-priced. Muffler layout has internal baffles which restriction the float of gases and cause returned stress. It reduces noise correctly with extra upward thrust in returned strain. Unwanted noise could be very dangerous to human ears; it also causes extreme headache and psychological strains. [6]

The analysis and designing of a muffler were relying of interest for maximum of the engineers. The analysis of muffler is basically accomplished using processes. The acoustic bench approach and the waft bench technique. The acoustic bench technique deals with the noise attenuation in case of small amplitude waves while the properties like temperature variant, pace, stress variation etc. are studied the use of

glide bench analysis.

Fig.(1) Below explains the running of all the key additives of an exhaust device used in vehicle "The important components used in a standard automobile exhaust machine are exhausted manifold, resonator, catalytic converter, exhaust pipe, muffler, tail pipe, 'Y' pipe, ball flanges".

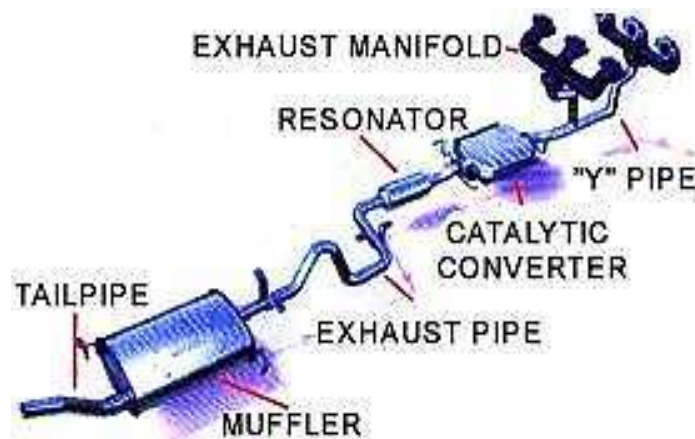

Fig. 1: Block diagram of Exhaust device

PROBLEM DESCRIPTION

Temperature variation of exhaust gases along the length of flow in reflective muffler.

APPROACH ADOPTED IN THIS PAPER DESIGN OF REFLECTIVE MUFFLER

Volume of Cylinder (V) = 796 cc
Swept Volume (Vs) = 795 cc

Hence the volume of muffler can be taken as 3.25 times of the swept volume (Vs), as given in the design data book.

Volume of Muffler (Vm) = 2583 cc

Dia. of Muffler (D) = 10.16 cm

Length of Muffler = 32 cm

Dia. Of Semi-Circular Plates = 10.10 cm

EXPERIMENTAL SETUP

The apparatus consists of a 4-stroke petrol

engine. It is a naturally aspirated 796 cc, 3 cylinders engine which delivers maximum power of 37 bhp at 500 rpm. A K-type thermocouple is used in order to measure the temperature of the exhaust gases coming out of the exhaust manifold. The thermocouple offers a temperature range till 1100°C. The muffler manufactured has a volume of 2583 cc.

The muffler consists of number of plates at specified interims. The temperature is noted at all the plates through the means of the thermocouple and the significant temperature drop is observed. The thermocouple is inserted inside the muffler at the specified openings before the plates. The temperature readings are taken at different rpm and the most optimum solution is obtained.

Table 1: Engine specification

1	Layout	3-cylinder, 796 cc, naturally aspirated
2	Maximum power	37 bhp at 500rpm
3	Maximum torque	6.01kgm at 2500 rpm
4	Specific output	46.48 bhp per litre
5	Power to weight	55.63 bhp per tonne
6	Torque to weight	9.03 kgm per tonne
7	Installation	Front, transverse, front wheel drive
8	Construction	Alloy head and cast-iron block
9	Bore/stroke	68.5/72.0 mm
10	Valve gear	2 per cylinder, SOHC
11	Compression ratio	8.8:1
12	Ignition and fuel	Transistorised ignition, multi-point petrol ignition

MANUFACTURING

Manufacturing process of muffler was carried away as follows



Fig. 2: Cutting of 4-inch diameter M.S. Pipe in lateral direction.



Fig. 3: Drilling of collars for making holes of nut & bolts.



Fig. 4: *Welding of collars on the semi - circular pipes.*



Fig. 5: *Welding of semi - circular plates.*



Fig. 6: *Fitting of Nut & Bolts.*

ANALYSIS

For silencer without plates

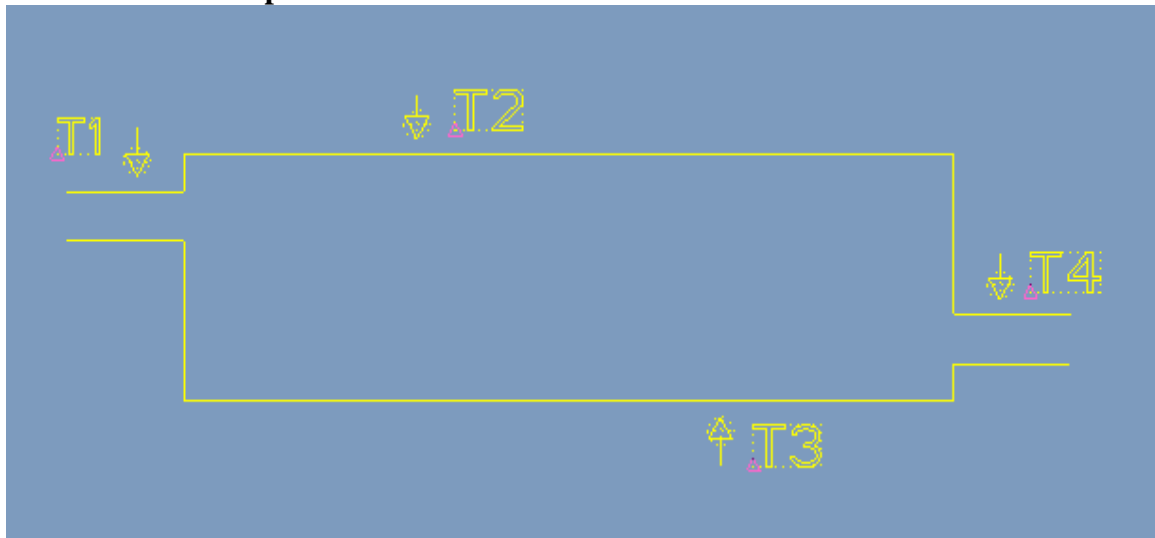

Fig. 7: shows muffler without plate. T1, T4 are inlet and outlet temperature and T2, T3 are the temperature variation between inlet and outlet measured by K type thermo-couple

Table 2: Engine at 500 RPM

T1	T2	T3	T4
274 °C	272 °C	272 °C	270 °C

Table 3: Engine at 1000 RPM

T1	T2	T3	T4
405 °C	402 °C	402 °C	400 °C

Table 4: Engine at 1500 RPM

T1	T2	T3	T4
575 °C	572 °C	571 °C	568 °C

FOR SILENCER WITH TWO PLATES

Plates inclined at 0° with vertical

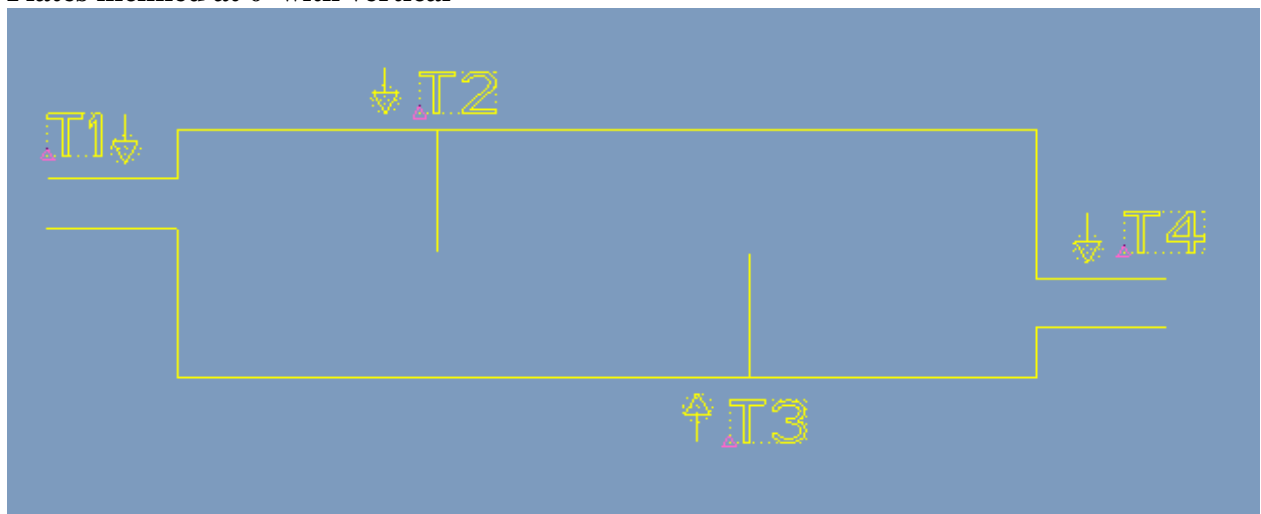

Fig. 8: shows muffler with two plates at 90°. T1, T4 are inlet and outlet temperature and T2, T3 are the temperature measured at plates

Table 5: Engine at 500 RPM

T1	T2	T3	T4
274 °C	186 °C	106 °C	60 °C

Table 6: Engine at 1000 RPM

T1	T2	T3	T4
405 °C	250 °C	152 °C	90 °C

Table 7: Engine at 1500 RPM

T1	T2	T3	T4
575 °C	323 °C	214 °C	120 °C

Plates inclined at 15° with vertical towards the direction of flow of exhaust gases.

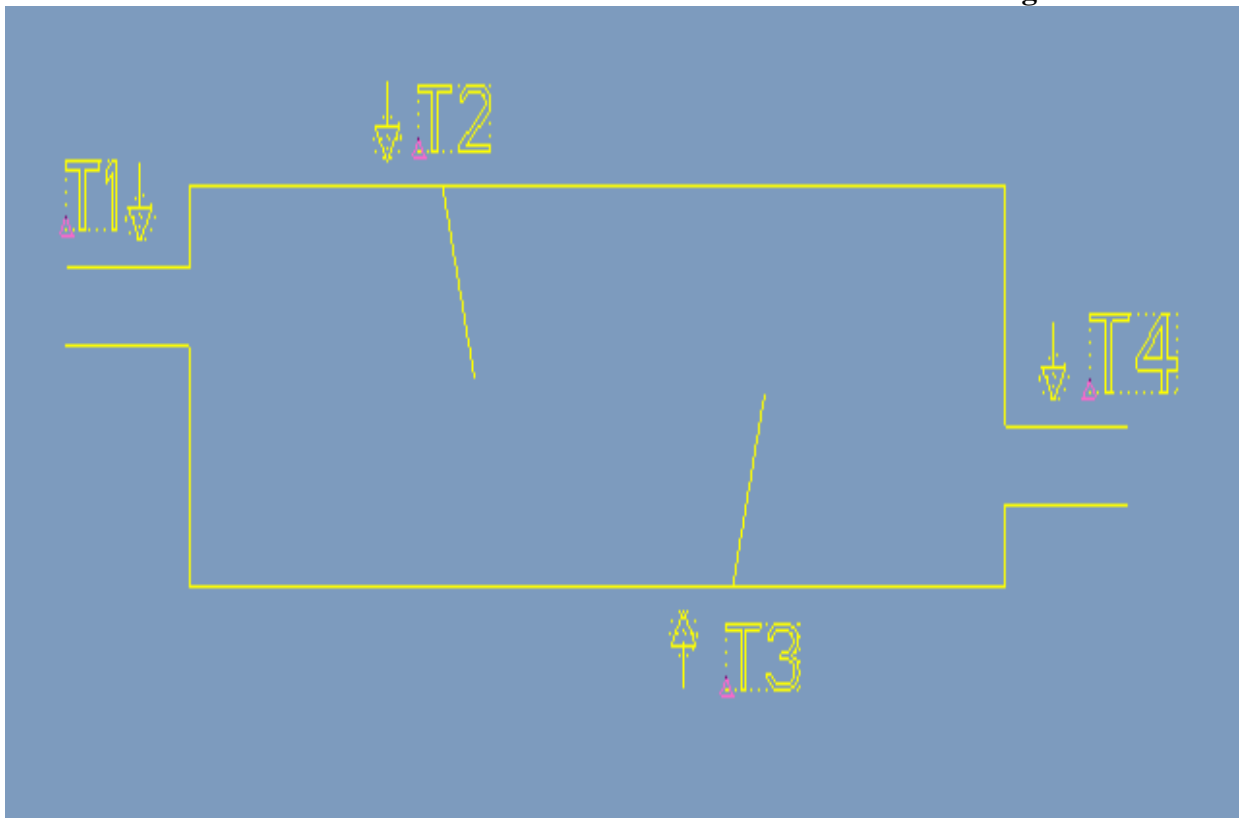

Fig. 9: shows muffler with two plates at 15° inclination. T1, T4 are inlet and outlet temperature and T2, T3 are the temperature measured at plates

Table 8: Engine at 500 RPM

T1	T2	T3	T4
274 °C	189 °C	112 °C	65 °C

Table 9: Engine at 1000 RPM

T1	T2	T3	T4
405 °C	274 °C	185 °C	105 °C

Table 10: Engine at 1500 RPM

T1	T2	T3	T4
575 °C	326 °C	218 °C	124

Plates inclined at 30° with vertical towards the direction of flow of exhaust gases.

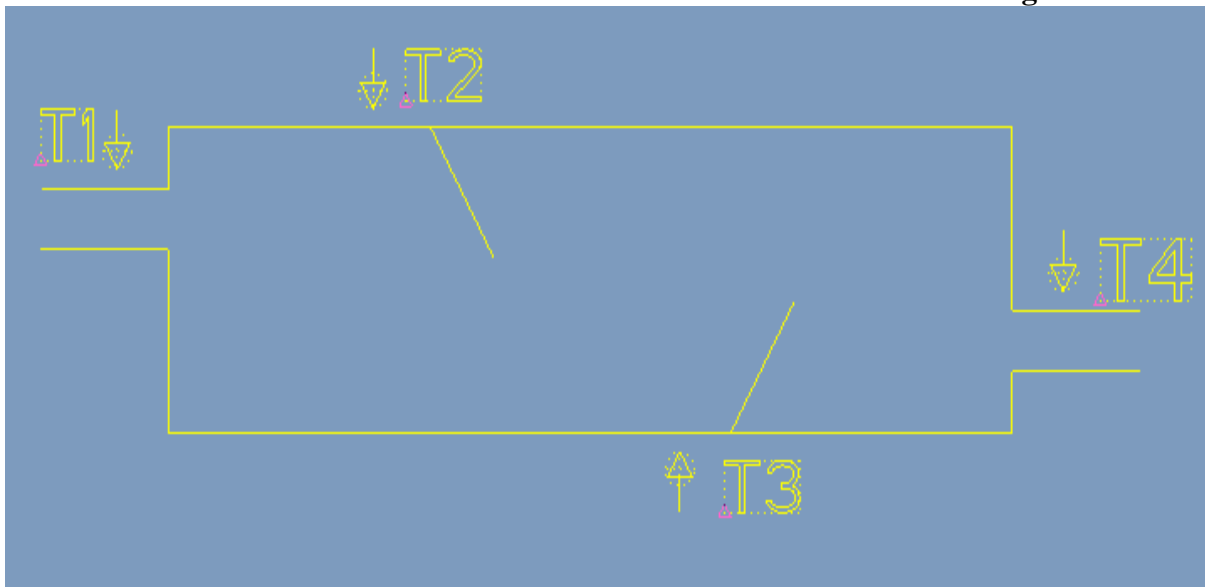

Fig.10: shows muffler with two plates at 30° inclination. T1, T4 are inlet and outlet temperature and T2, T3 are the temperature measured at plates

Table 11: Engine at 500 RPM

T1	T2	T3	T4
274 °C	193 °C	117 °C	68 °C

Table 12: Engine at 1000 RPM

T1	T2	T3	T4
405 °C	287 °C	210 °C	127 °C

Table 13: Engine at 1500 RPM

T1	T2	T3	T4
575 °C	334 °C	230 °C	141 °C

Plates inclined at 45° with vertical towards the direction of flow of exhaust gases.

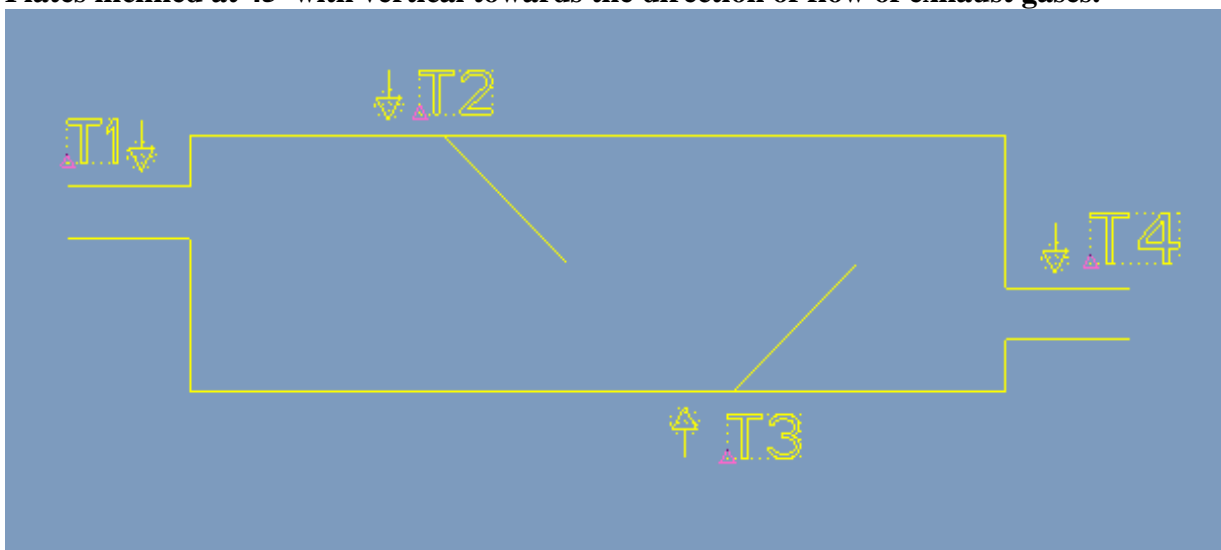

Fig. 11: shows muffler with two plates at 45° inclination. T1, T4 are inlet and outlet temperature and T2, T3 are the temperature measured at plates

Table 14: Engine at 500 RPM

T1	T2	T3	T4
274 °C	195 °C	121 °C	71 °C

Table 15: Engine at 1000 RPM

T1	T2	T3	T4
405 °C	295 °C	225 °C	135 °C

Table 16: Engine at 1500 RPM

T1	T2	T3	T4
575 °C	340 °C	242 °C	150 °C

Plates Inclined At 15° With Vertical Against The Direction Of Flow Of Exhaust Gases.

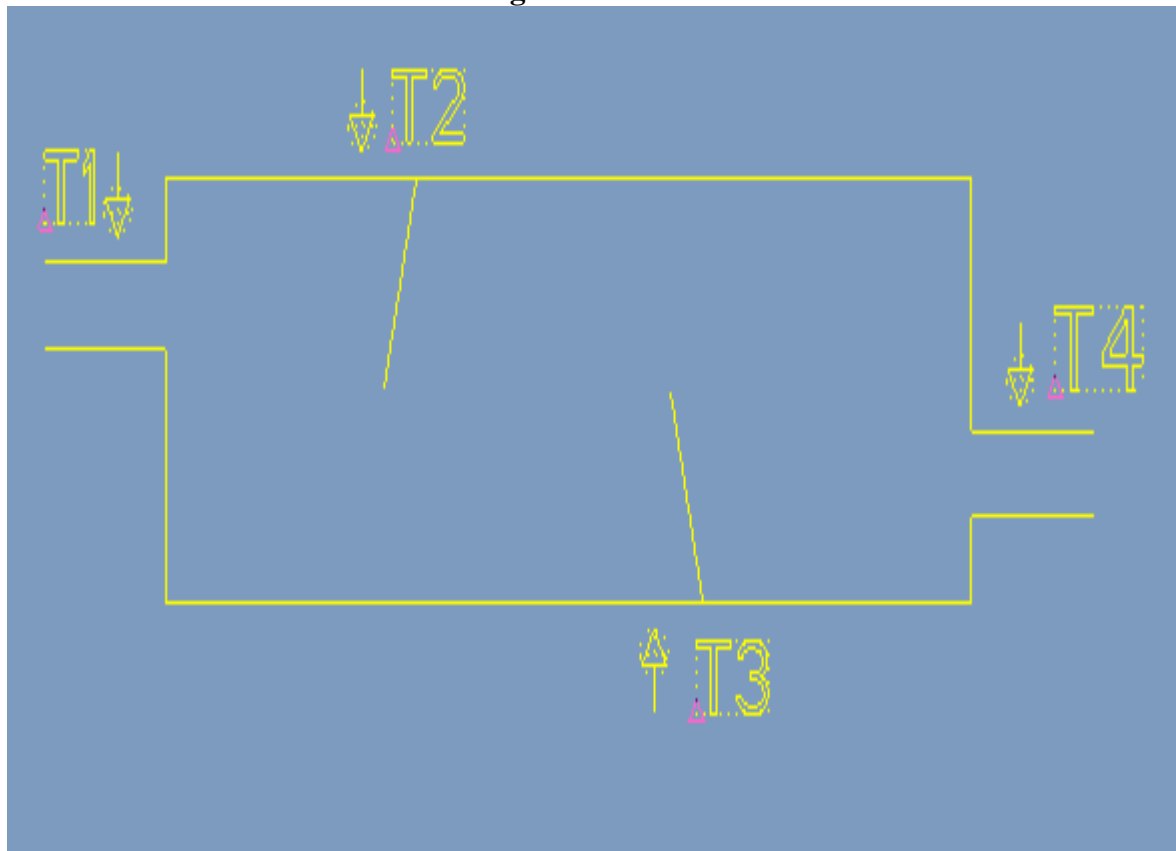

Fig.12: shows muffler with two plates at 15° inclination. T1, T4 are inlet and outlet temperature and T2, T3 are the temperature measured at plates

Table 17: Engine at 500 RPM

T1	T2	T3	T4
274 °C	183 °C	101 °C	57 °C

Table 18: Engine at 1000 RPM

T1	T2	T3	T4
405 °C	242 °C	148 °C	88 °C

Table 19: Engine at 1500 RPM

T1	T2	T3	T4
575 °C	318 °C	210 °C	116

Plates inclined at 30° with vertical against the direction of flow of exhaust gases.

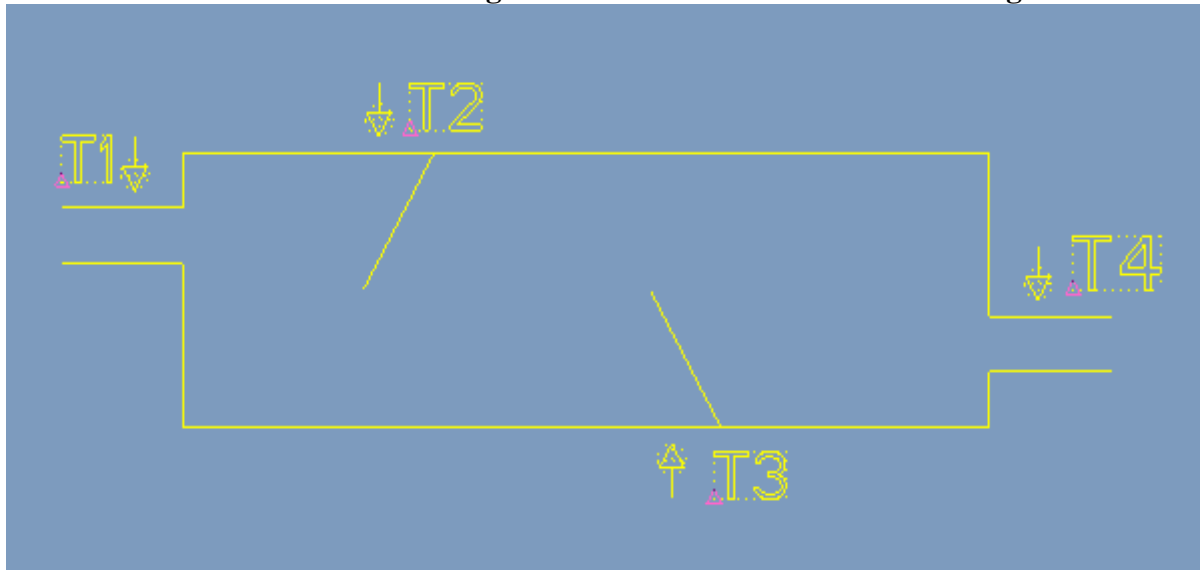

Fig. 13: shows muffler with two plates at 30° inclination. T1, T4 are inlet and outlet temperature and T2, T3 are the temperature measured at plates

Table 20: Engine at 500 RPM

T1	T2	T3	T4
274 °C	180 °C	98 °C	55 °C

Table 21: Engine at 1000 RPM

T1	T2	T3	T4
405 °C	237 °C	140 °C	85 °C

Table 22: Engine at 1500 RPM

T1	T2	T3	T4
575 °C	314 °C	205 °C	112 °C

Plates inclined at 45° with vertical against the direction of flow of exhaust gases.

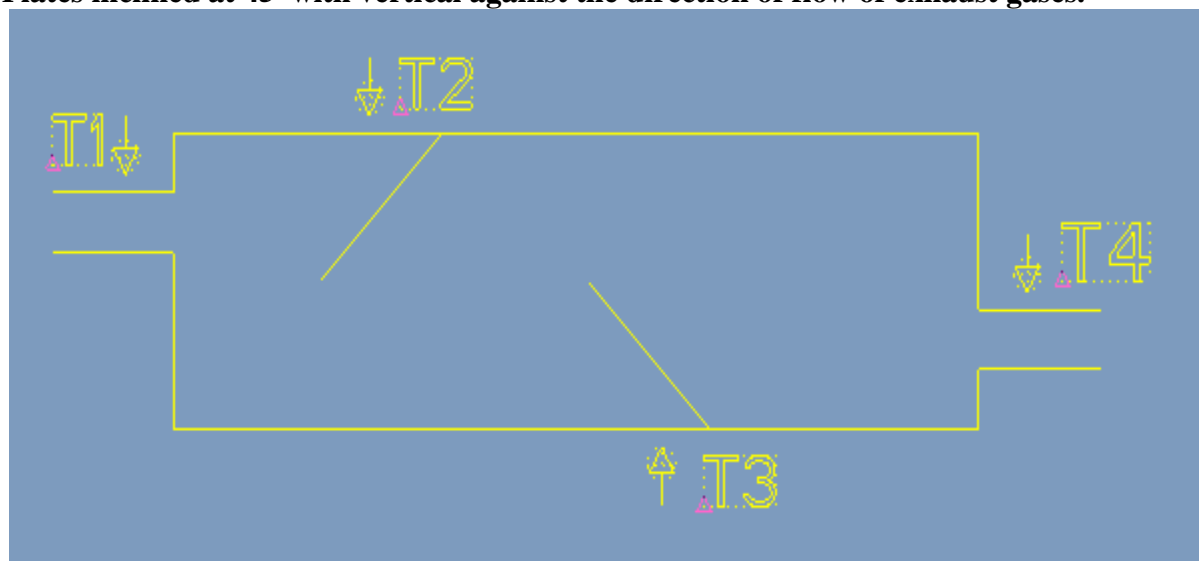

Fig. 14: shows muffler with two plates at 45° inclination. T1, T4 are inlet and outlet temperature and T2, T3 are the temperature measured at plates

Table 23: Engine at 500 RPM

T1	T2	T3	T4
274 °C	177 °C	95 °C	51 °C

Table 24: Engine at 1000 RPM

T1	T2	T3	T4
405 °C	232 °C	136 °C	82 °C

Table 25: Engine at 1500 RPM

T1	T2	T3	T4
575 °C	312 °C	200 °C	108 °C

For Silencer With Three Plates Plates inclined at 0° with vertical

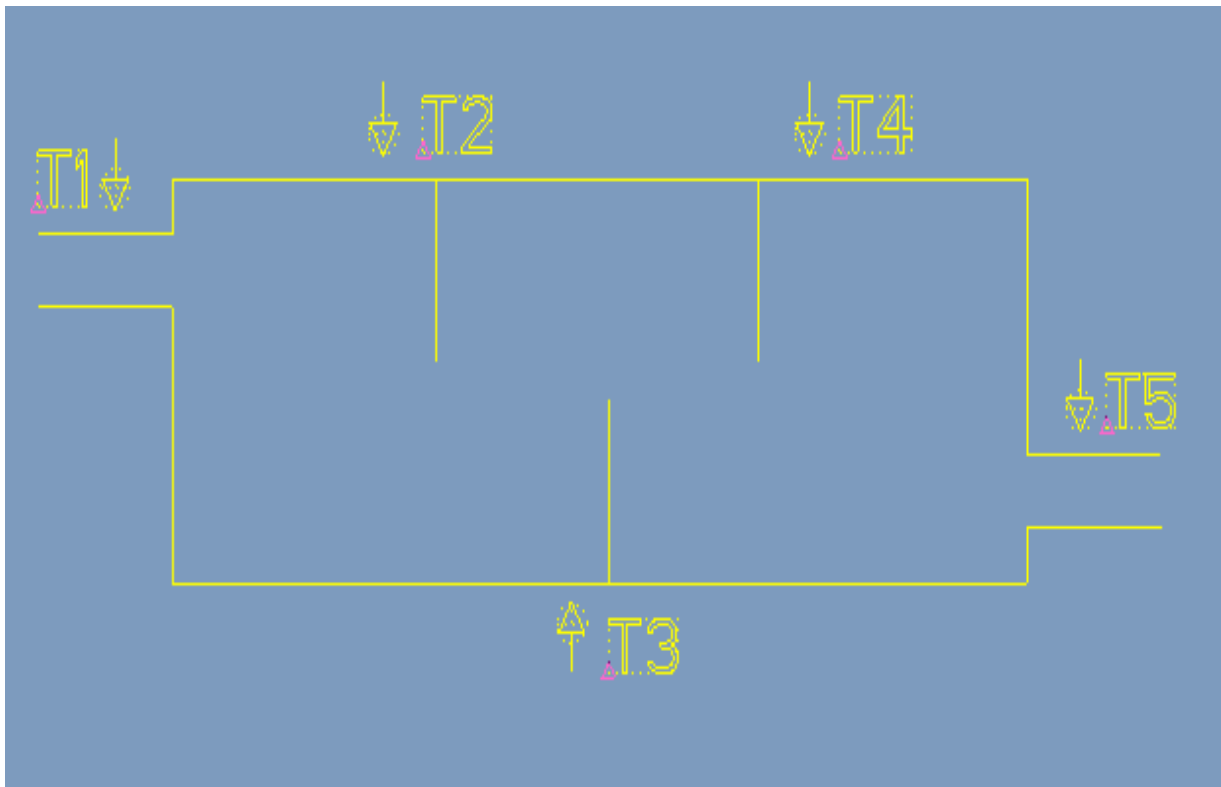

Fig. 15: shows muffler with three plates at 90° inclination. T1, T5 are inlet and outlet temperature and T2, T3, T4 are the temperature measured at plates

Table 26: Engine at 500 RPM

T1	T2	T3	T4	T5
274°C	198°C	124°C	86°C	55°C

Table 27: Engine at 1000 RPM

T1	T2	T3	T4	T5
405°C	242°C	194°C	146°C	85°C

Table 28: Engine at 1500 RPM

T1	T2	T3	T4	T5
575°C	326°C	229°C	171°C	114°C

Plates inclined at 15° with vertical towards the direction of flow of exhaust gases.

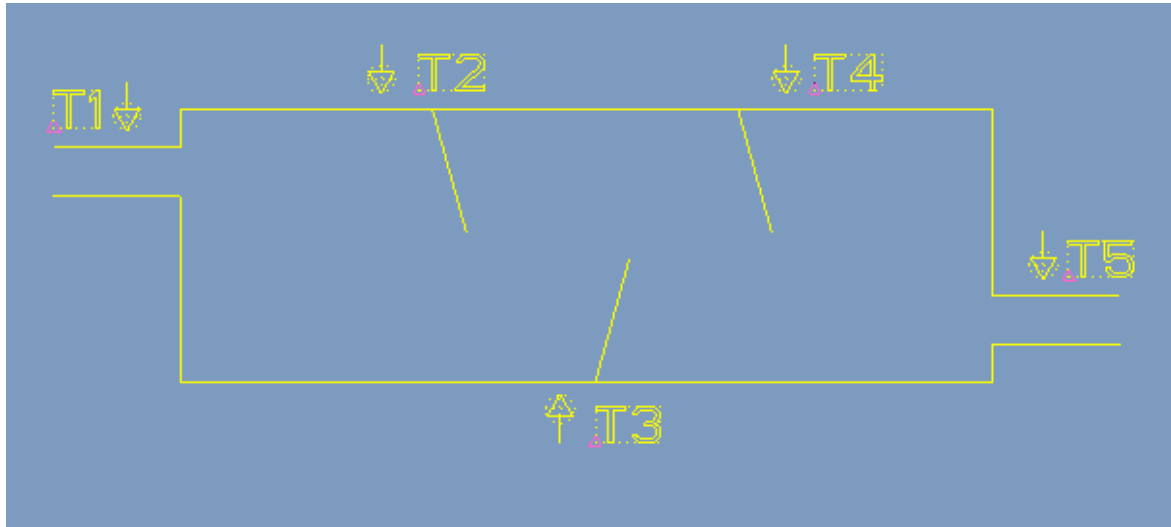

Fig.16: shows muffler with three plates at 15° inclination. T1, T5 are inlet and outlet temperature and T2, T3, T4 are the temperature measured at plates

Table 29: Engine at 500 RPM

T1	T2	T3	T4	T5
274°C	201°C	128°C	89°C	60°C

Table 30: Engine at 1000 RPM

T1	T2	T3	T4	T5
405°C	280°C	210°C	158°C	98°C

Table 31: Engine at 1500 RPM

T1	T2	T3	T4	T5
575°C	328°C	231°C	174°C	116°C

Plates inclined at 30° with vertical towards the direction of flow of exhaust gases.

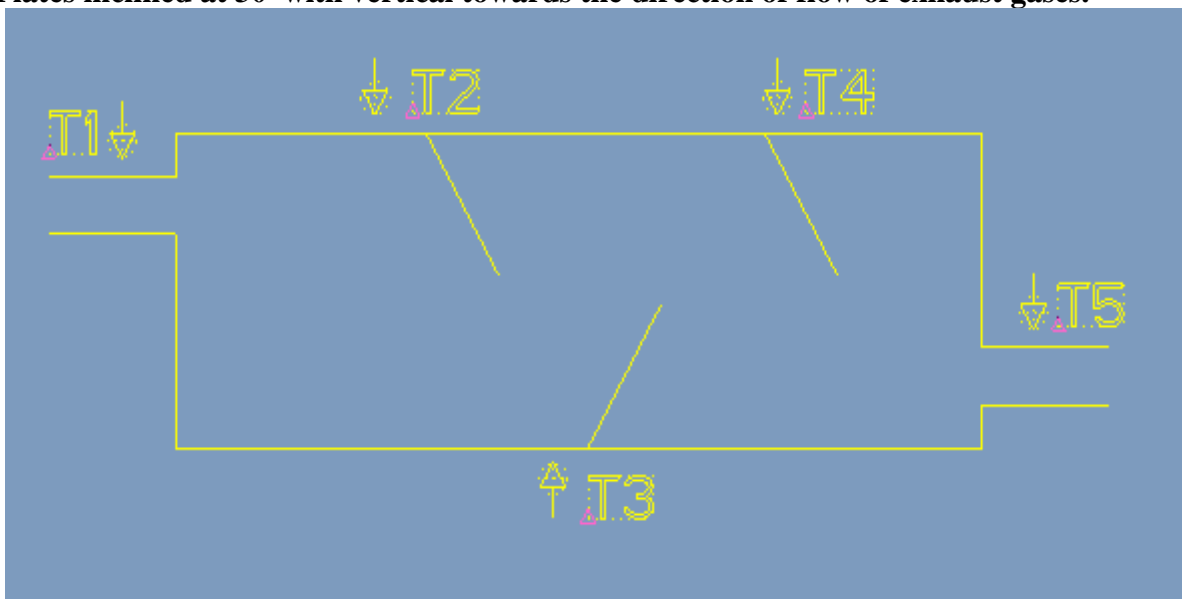

Fig. 17: shows muffler with three plates at 30° inclination. T1, T5 are inlet and outlet temperature and T2, T3, T4 are the temperature measured at plates

Table 32: Engine at 500 RPM

T1	T2	T3	T4	T5
274°C	207°C	134°C	95°C	64°C

Table 33: Engine at 1000 RPM

T1	T2	T3	T4	T5
405°C	300°C	225°C	180°C	115°C

Table 34: Engine at 1500 RPM

T1	T2	T3	T4	T5
575°C	336°C	242°C	187°C	129°C

Plates inclined at 45° with vertical towards the direction of flow of exhaust gases.

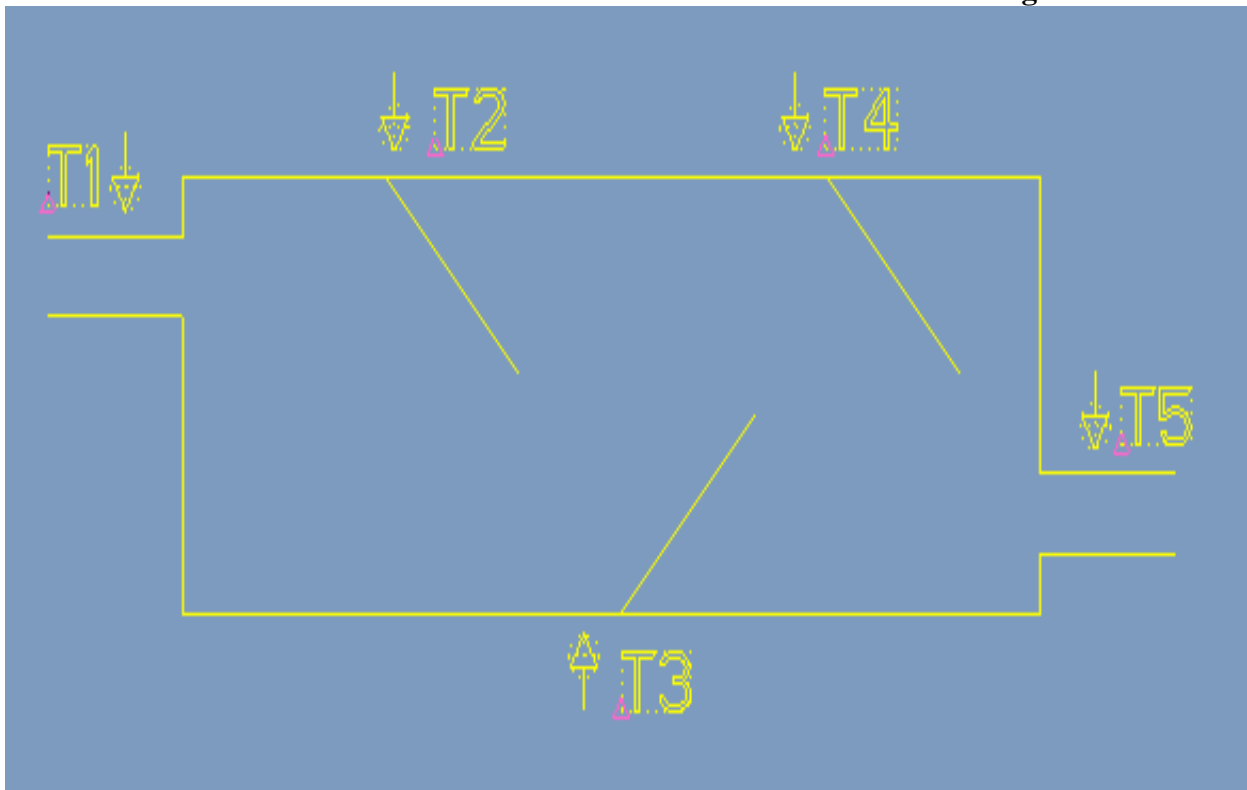

Fig.18

Table 35: Engine at 500 RPM

T1	T2	T3	T4	T5
274°C	210°C	138°C	101°C	68°C

Table no – 35 shows muffler with three plate at 45° inclination. T1, T5 are inlet and outlet temperature and T2, T3, T4 are the temperature measured at plates

Table 36: Engine at 1000 RPM

T1	T2	T3	T4	T5
405°C	312°C	237°C	198°C	130°C

Table 37: Engine at 1500 RPM

T1	T2	T3	T4	T5
575°C	344°C	250°C	196°C	142°C

Plates inclined at 15° with vertical against the direction of flow of exhaust gases.

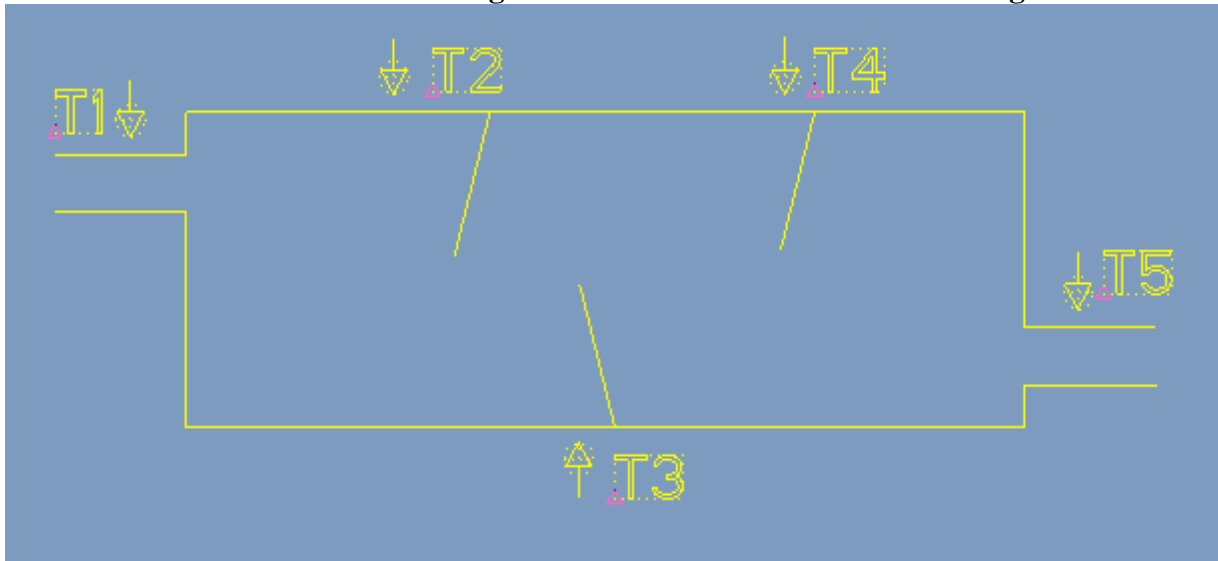

Fig. 19: shows muffler with three plates at 15° inclination. T1, T5 are inlet and outlet temperature and T2, T3, T4 are the temperature measured at plates

Table 38: Engine at 500 RPM

T1	T2	T3	T4	T5
274°C	195°C	121°C	82°C	51°C

Table 39: Engine at 1000 RPM

T1	T2	T3	T4	T5
405°C	240°C	190°C	142°C	82°C

Table 40: Engine at 1500 RPM

T1	T2	T3	T4	T5
575°C	324°C	227°C	168°C	112°C

Plates inclined at 30° with vertical against the direction of flow of exhaust gases.

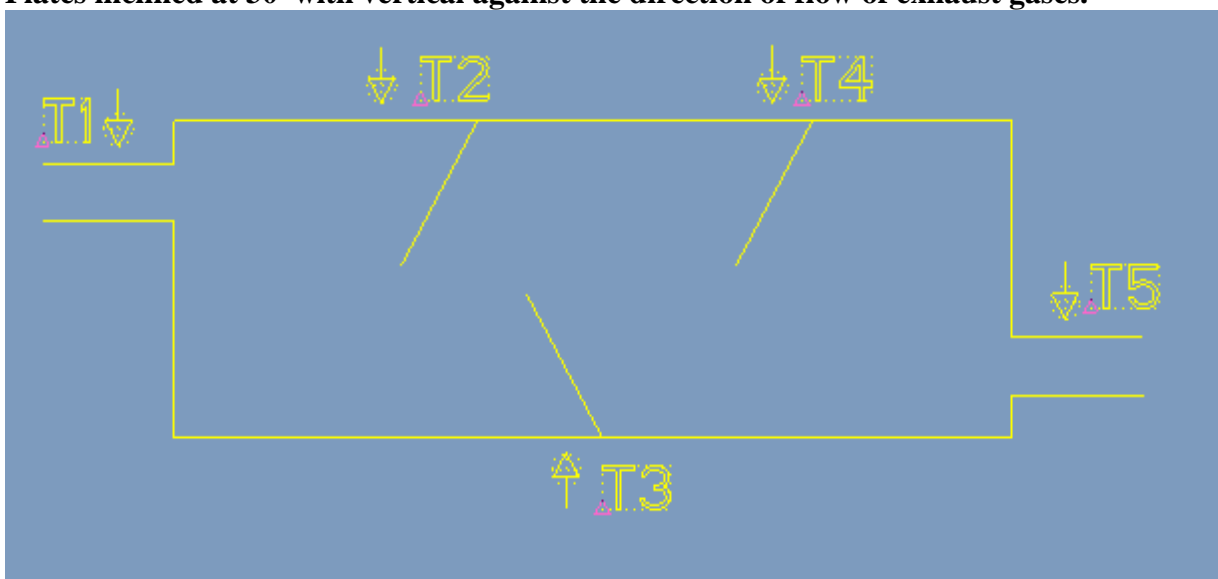

Fig. 20: shows muffler with three plates at 30° inclination. T1, T5 are inlet and outlet temperature and T2, T3, T4 are the temperature measured at plates

Table 41: Engine at 500 RPM

T1	T2	T3	T4	T5
274°C	191°C	118°C	79°C	49°C

Table 42: Engine at 1000 RPM

T1	T2	T3	T4	T5
405°C	236°C	185°C	132°C	78°C

Table 43: Engine at 1500 RPM

T1	T2	T3	T4	T5
575°C	322°C	223°C	162°C	108°C

Plates inclined at 45° with vertical against the direction of flow of exhaust gases.

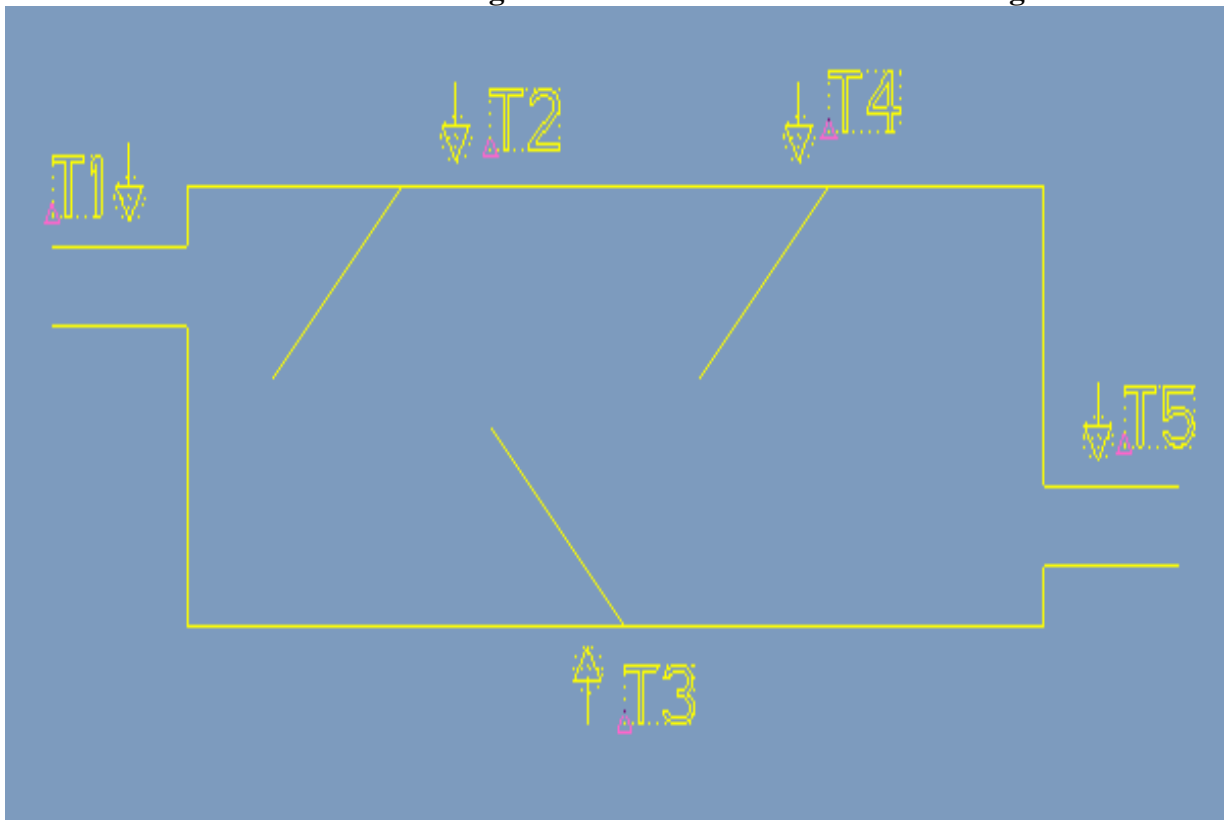

Fig. 21: shows muffler with three plates at 45° inclination. T1, T5 are inlet and outlet temperature and T2, T3, T4 are the temperature measured at plates

Table 44: Engine at 500 RPM

T1	T2	T3	T4	T5
274°C	188°C	113°C	75°C	46°C

Table 45: Engine at 1000 RPM

T1	T2	T3	T4	T5
405°C	230°C	178°C	127°C	75°C

Table 46: Engine at 1500 RPM

T1	T2	T3	T4	T5
575°C	318°C	216°C	158°C	102°C

RESULTS

Table 47: Engine at 500 RPM

Plates		Angle with vertical							
		Towards The Direction Of Flow				Against the Direction Of Flow			
		0°	15°	30°	45°	0°	15°	30°	45°
Three	Measured data (temp. drop) °C	219	214	210	206	219	213	225	228
Two	Measured data (temp. drop) °C	214	209	206	203	214	217	219	223
Zero	Measured data (temp. drop) °C	4							
<p>Table no – 47 shows that when number of plate’s increases with the inclination towards the direction of flow increases the temperature drop. Maximum temperature difference in three plate’s muffler is 13°, while in two plates it’s about 11°. It’s also shows that vice versa happened when the plates are attached against the direction of exhaust gases.</p>									

Table 48: Engine at 1000 RPM

Plates		Angle with vertical							
		Towards The Direction Of Flow				Against The Direction Of Flow			
		0°	15°	30°	45°	0°	15°	30°	45°
Three	Measured data (temp. drop) °C	320	307	290	275	320	323	327	330
Two	Measured data (temp. drop) °C	315	300	278	270	315	317	320	323
Zero	Measured data (temp. drop) °C	5							
<p>Table no –48 shows that with increase in rpm, inclination and plates, temperature drop increases and when the plates are installed against the direction of flow with similar constraints temperature difference is increasing</p>									

Table 49: Engine at 1500 RPM

Plates		Angle with vertical							
		Towards the Direction Of Flow				Against the Direction Of Flow			
		0°	15°	30°	45°	0°	15°	30°	45°
Three	Measured data (temp. drop) °C	461	459	446	433	461	463	467	473
Two	Measured data (temp. drop) °C	455	451	434	425	455	459	463	467
Zero	Measured data (temp. drop) °C	7							
<p>Table no -49 show that further increase in rpm temperature difference is more in three plates compared with two and no plate.</p>									

CONCLUSION

Our aim with this research paper is to reduce the outlet temperature of exhaust gases by changing the internal structure of muffler. For this purpose, reflective type muffler is designed. Overall dimension of mufflers tested were not been manipulated,

its same in every test by varying the RPM of engine. Angle of plates mounted, towards the direction of flow and opposite to the direction of flow of exhaust gases in the muffler was varied. For testing the mufflers 3-cylinder petrol engine is used.

The Temperature Drop Increases As the Number of Plates Increases.

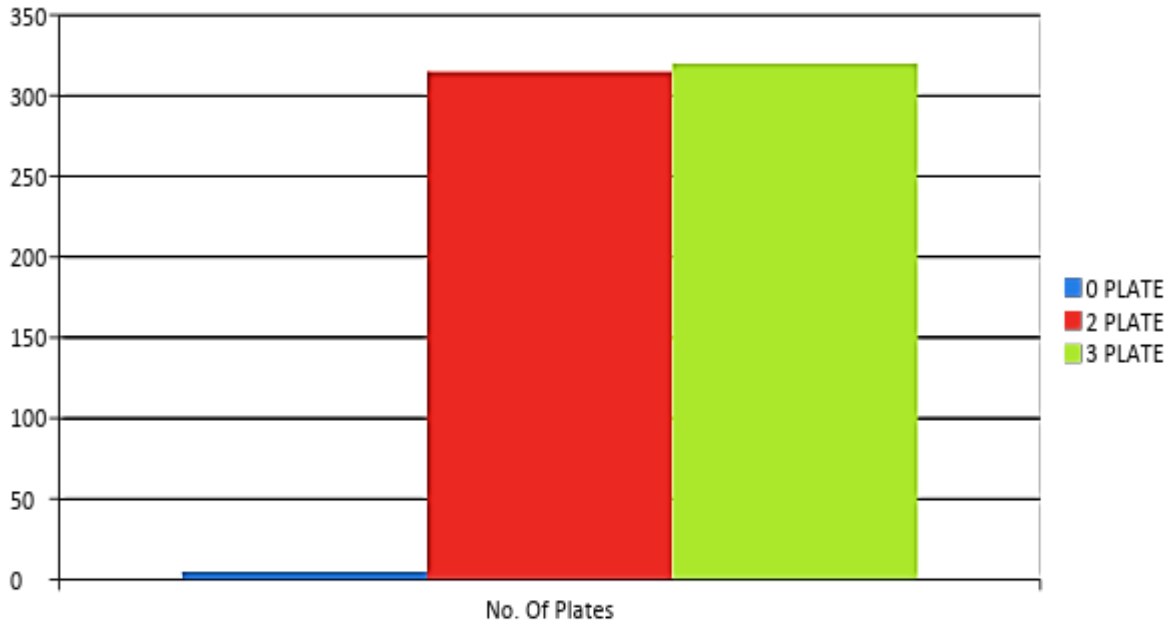

Graph-1 (For silencer with plates inclined at 0° with vertical at 1000 RPM)

The Temperature Drop Increases As the Inclination of Plates Increases.

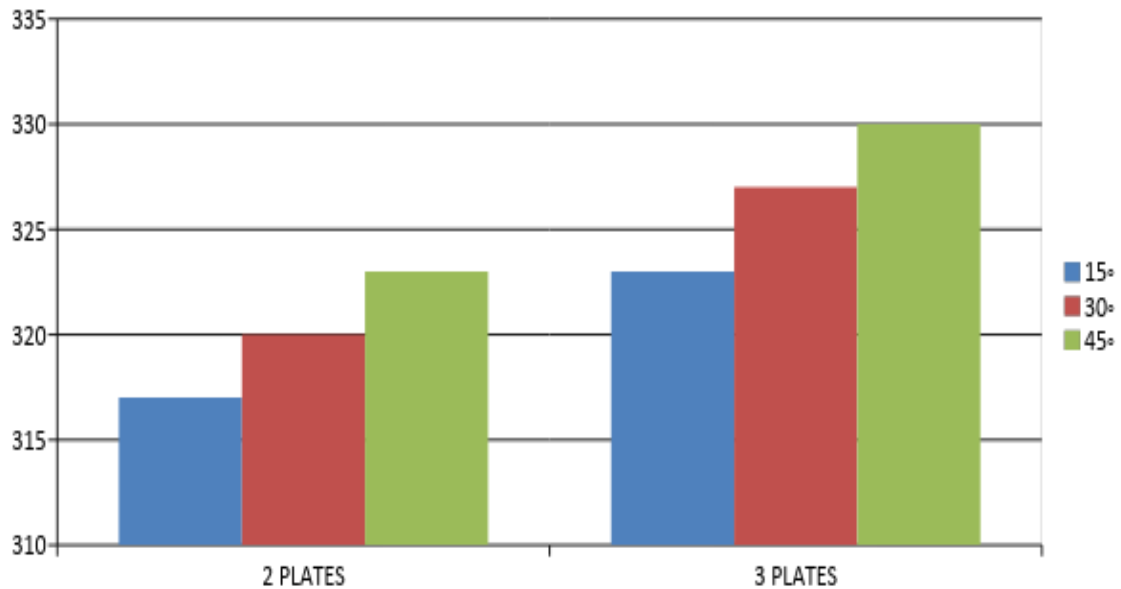

Graph-2 (For silencer with 2, 3 plates at 1000 RPM against the direction of flow)

The temperature drop increases as the plates are inclined against the direction of flow of exhaust gases and vice-versa.

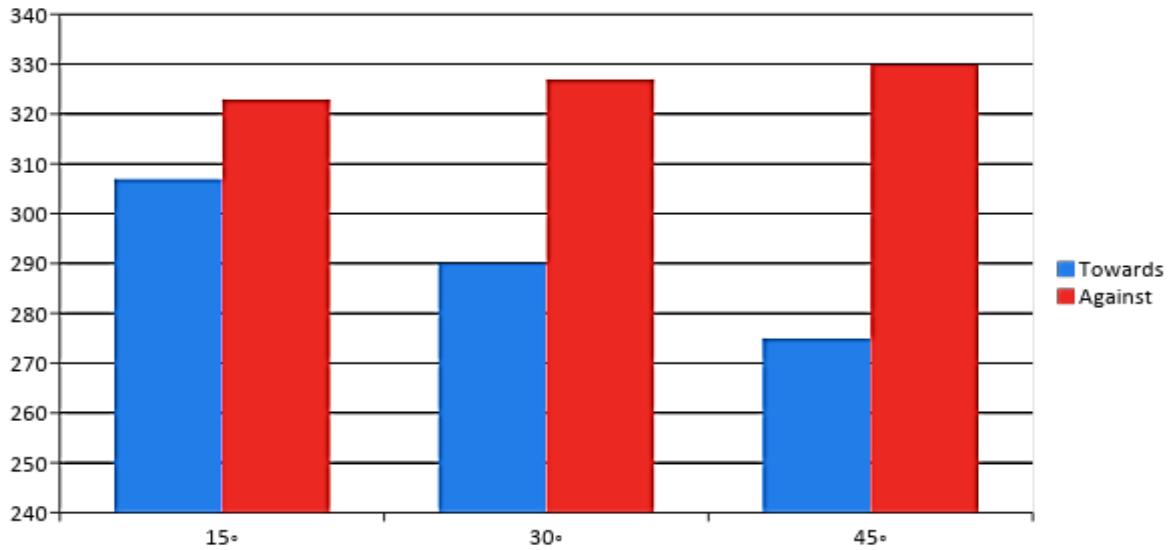

Graph-3 (For silencer with 3 plates at 1000 RPM)

The temperature drop increases as the RPM of engine increases.

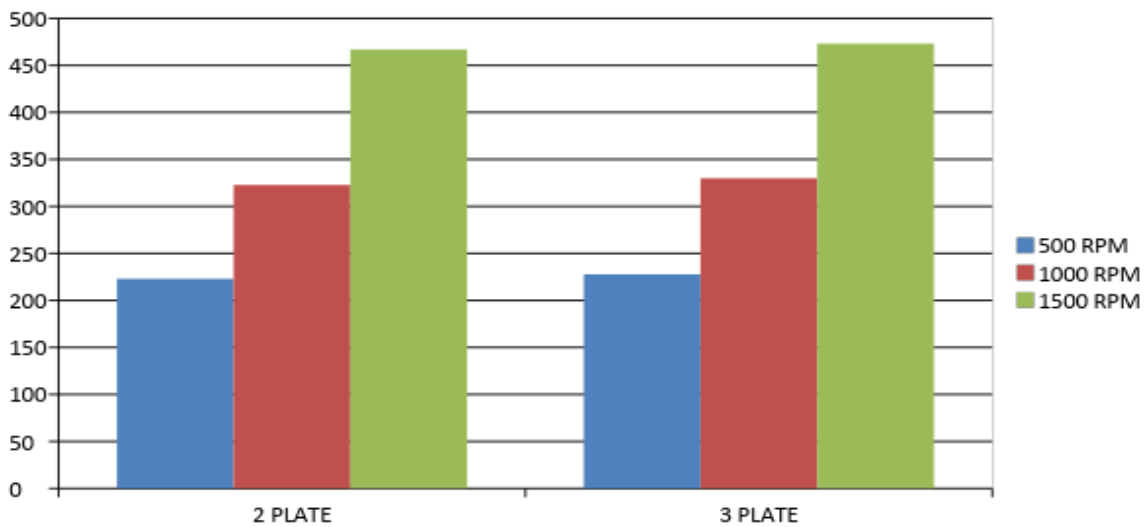

Graph-4 (For silencer with 2, 3 plates inclined at 45° against the direction of flow of exhaust gas)

REFERENCES

1. Yash K. Kakadiya¹, Prof. B.S. Patel², Prof. J.P. Hadiya³: Design and Comparison of Mufflers Having Different Arrangements for Diesel Engine, (SSRG International Journal of Mechanical Engineering (SSRG - IJME) – Volume 4 Issue 6 June 2017 ISSN: 2348 – 8360

www.internationaljournalssrg.org
Page 24

2. (Muffler Design for Automotive Exhaust Noise Attenuation - A Review Mr.Jigar H. Chaudhri, Prof. Bharat S. Patel, Prof.Satish A. Shah 1PG Student, 2Asso.Prof, 3Asso.Prof Mechanical Engineering department, BVM Engineering college, Vallabh Vidhyanagar, Anand, Gujarat, India).

3. *Mara Cuesta, Pedro Cobo: Active Control of the Exhaust Noise Radiated by an Enclosed Generator [J]. Applied Acoustics,2000(61),p.83-94.)*
4. *A Study on Exhaust Muffler Using a Mixture of Counter phase Counteract and Split-gas Rushing Ying-li Shao*) (General design principles for an automotive mufflers)*
5. *(IARJSET ISSN (Online) 2393-8021 ISSN (Print) 2394-1588 International Advanced Research Journal in Science, Engineering and Technology CETCME-2017 "Cutting Edge Technological Challenges in Mechanical Engineering" Noida Institute of Engineering & Technology (NIET), Greater Noida Vol. 4, Special Issue 3, February 2017 Copyright to IARJSET DOI 10.17148/IARJSET 24 A Study on Effectiveness of Muffler on a Two-wheeler vehicle Noise Jashanpreet Singh¹, S. P. Nigam², L. K. Bhagi³ Assistant Professor, Aryabhata Group of Institutes, Barnala (Punjab), India¹ Visiting Professor, Thapar University, Patiala (Punjab), India² Independent Researcher³)*